

EAM300-SM6.5UC6.14180.A

Solid shaft with synchro flange, magnetic multiturn encoders 14 bit ST / 18 bit MT

Article number: 11273672

Overview

- Encoder multiturn / CANopen®
- Precise magnetic sensing
- Angular accuracy up to $\pm 0.15^\circ$
- Protection IP 65
- High resistance to shock and vibrations
- Electronic gear function
- Axial cable connection



Technical data

Technical data - electrical ratings

Voltage supply	10...30 VDC
Consumption typ.	20 mA (24 VDC, w/o load)
Initializing time	≤ 170 ms after power on
Data currency	< 1 ms
Interface	CANopen®
Function	Multiturn
Profile conformity	CANopen® CiA communication profile DS 301, LSS profile DSP 305, device profile DS 406, DS 417
Steps per revolution	16384 / 14 bit
Number of revolutions	262144 / 18 bit
Absolute accuracy	$\pm 0.15^\circ$ (+20 $\pm 15^\circ$ C) $\pm 0.25^\circ$ (-40...+85 $^\circ$ C)
Sensing method	Magnetic
Code sequence	CW: ascending values with clockwise sense of rotation (looking at flange)
Output stages	CAN-Bus, LV (3.3 V) compatible ISO 11898
Interference immunity	EN 61000-6-2
Emitted interference	EN 61000-6-3 (cable length < 30 m, no connection to DC network) EN 61000-6-4

Technical data - electrical ratings

Approval UL approval / E217823

Technical data - mechanical design

Size (flange)	$\varnothing 30$ mm
Shaft type	$\varnothing 6 \times 12$ mm solid shaft
Flange	Synchro flange
Protection EN 60529	IP 65 (without shaft seal)
Operating speed	≤ 6000 rpm
Starting torque	≤ 0.75 Ncm (+20 $^\circ$ C)
Moment of inertia	0.98 gcm ²
Admitted shaft load	≤ 10 N axial ≤ 10 N radial
Material	Housing: steel zinc-coated Flange: aluminium Shaft: stainless steel
Operating temperature	-40...+85 $^\circ$ C (see general information)
Relative humidity	95 %
Resistance	EN 60068-2-6 Vibration 30 g, 10-2000 Hz EN 60068-2-27 Shock 500 g, 1 ms
Weight approx.	150 g
Connection	Cable 2 m

Optional

- Terminating resistor

EAM300-SM6.5UC6.14180.A

Solid shaft with synchro flange, magnetic multiturn encoders 14 bit ST / 18 bit MT

Article number: 11273672

General information

Self-heating interrelated to speed, protection, attachment method and ambient conditions as well electronics and supply voltage must be considered for precise thermal dimensioning. Self-heating is supposed to approximate 6 K (standstill) and additionally for movement 1.5 K per 1000 rpm (IP 65) or 3.5 K per 1000 rpm (IP 67). Operating the encoder close to the maximum limits requires measuring the real prevailing temperature at the encoder flange.

Terminal assignment

Cable

 for connection reference **-L** and **-U**

Core colour	Signal
brown	+Vs
white	0 V
green	CAN_H
yellow	CAN_L
grey	CAN_GND
pink	n.c.
blue	n.c.
red	n.c.
Screen: connected to housing	
Cable data: 8 x 0.09 mm ²	

CANopen® features

Operating modes	Time-driven (Event-Time) Synchronously triggered (Sync)
Node Monitoring	Heartbeat Node guarding
Programmable parameters	Operating modes Total resolution Scaling Electronic gear function
Diagnosis	Multiturn sensing Position error Temperature exceeding Speed exceeding
Default	50 kbit/s, Node-ID 1 (DS406)

EAM300-SM6.5UC6.14180.A

Solid shaft with synchro flange, magnetic multiturn encoders 14 bit ST / 18 bit MT

Article number: 11273672

Dimensions

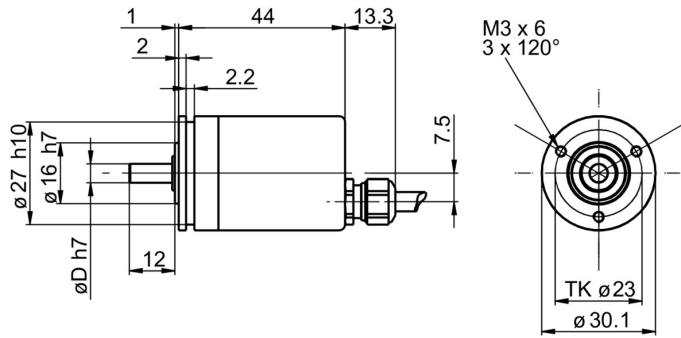

Cable, axial, IP 65

EAM300-SM6.5UC6.14180.A

Solid shaft with synchro flange, magnetic multiturn encoders 14 bit ST / 18 bit MT

Article number: 11273672

Accessories

Mounting accessories

10106004 Clamp set \varnothing 10 mm