

## Overview

- Most secure object detection due to the barrier principle
- Manipulation-proof, simple teach-in via qTeach or line teach
- IO-Link for extended parameterization options and additional diagnostic data
- Quick mounting by means of M3 threaded bushes made of stainless steel



Picture similar



## Technical data

General data		Electrical data	
Type	Through beam sensor	Output circuit	Push-pull
Emitter / receiver	Receiver	Output current	50 mA
Light source	Use with pulsed red laser diode	Short circuit protection	Yes
Actual range Sb	5 m	Reverse polarity protection	Yes
Nominal range Sn	6 m	<b>Communication interface</b>	
Smallest object recognizable typ.	3 mm (0,5 mm with aperture)	Baud rate	230,4 kBaud (COM 3)
Alignment / soiled lens indicator	Flashing output indicator	Adjustable parameters	Switching point Time filters LED status indicators Output logic Counter Deactivate the sensor element Find Me function Teach-in mode
Output indicator	LED yellow	IO-Link port type	Class A
Power on indication	LED green	Process data length	32 Bit
Sensitivity adjustment	Teach-in and IO-Link	Process data structure	Bit 0 = SSC1 (presence) Bit 2 = quality Bit 3 = alarm Bit 5 = SSC4 (counter) Bit 16-31 = 16 Bit measurement
Suppression of reciprocal influence	Yes	Interface	IO-Link V1.1
<b>Electrical data</b>		Additional data	Signal strength Excess gain Operating cycles Device temperature
Response time / release time	< 0.1 ms < 0.12 ms	Cycle time	≥ 0.6 ms
Jitter	< 0.03 ms < 0.05 ms		
Voltage supply range +Vs	10 ... 30 VDC		
Current consumption max. (no load)	20 mA (@ 10 VDC)		
Current consumption typ.	10 mA (@ 24 VDC)		
Voltage drop Vd	<2 VDC		
Output function	Light / dark operate		

# O200.EL-GW1J.72CV/FREC\_H006

Through beam sensors - miniature

Article number: 11230138

## Technical data

### Mechanical data

Width / diameter	8 mm
Height / length	25.1 mm
Depth	14.1 mm
Design	Rectangular
Mechanical mounting	Threaded sleeves M3 (stainless steel)
Housing material	Plastic (ASA, PMMA)

### Mechanical data

Front (optics)	PMMA
Connection types	Cable 4 pin, 2 m
Cable characteristics	PVC / PVC 4 x 0.08 mm <sup>2</sup>

### Ambient conditions

Operating temperature	-25 ... +50 °C
Protection class	IP 67

## Technical drawings

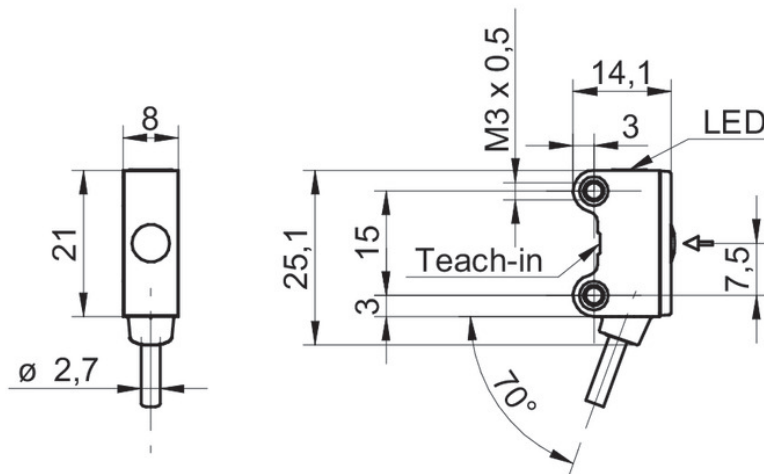

## Connection diagram

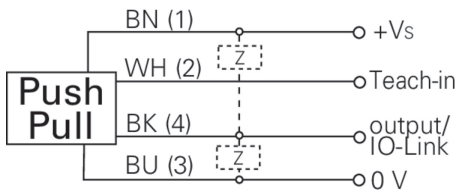

## Excess gain curve

