

## HOG 161

Through hollow shaft  $\varnothing 38 \dots 75$  mm  
250...2500 pulses per revolution

### Overview

- Robust light-metal housing
- Through hollow shaft up to  $\varnothing 75$  mm
- Output stage HTL or TTL
- Output stage TTL with regulator UB 9...26 VDC
- Special protection against corrosion
- Large terminal box, turn by 180°

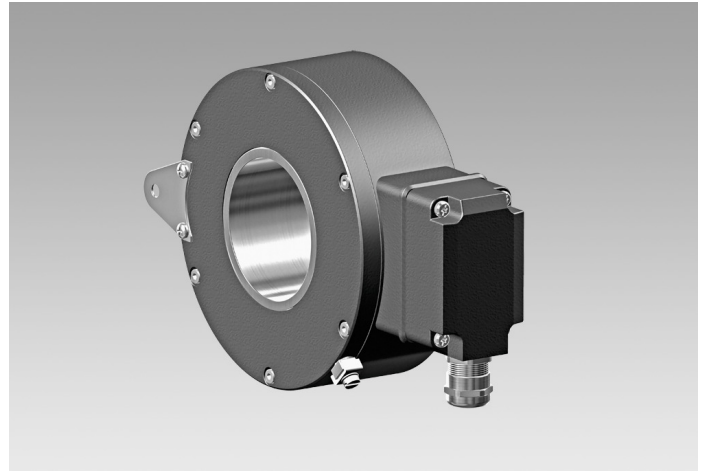

### Technical data

#### Technical data - electrical ratings

Voltage supply	9...30 VDC 5 VDC $\pm 5$ % 9...26 VDC
Consumption w/o load	$\leq 100$ mA
Pulses per revolution	250 ... 2500
Phase shift	$90^\circ \pm 20^\circ$
Duty cycle	40...60 %
Reference signal	Zero pulse, width $90^\circ$
Sensing method	Optical
Output frequency	$\leq 120$ kHz
Output signals	K1, K2, K0 + inverted
Output stages	HTL TTL/RS422
Interference immunity	EN 61000-6-2
Emitted interference	EN 61000-6-3
Approval	CE UL approval / E217823

#### Technical data - mechanical design

Size (flange)	$\varnothing 158$ mm
Shaft type	$\varnothing 38 \dots 75$ mm (through hollow shaft)
Admitted shaft load	$\leq 350$ N axial $\leq 500$ N radial

#### Technical data - mechanical design

Protection EN 60529	IP 54
Operating speed	$\leq 6000$ rpm (mechanical)
Operating torque typ.	15 Ncm
Rotor moment of inertia	26.3 kgcm <sup>2</sup> ( $\varnothing 48$ ) 13.5 kgcm <sup>2</sup> ( $\varnothing 75$ )
Material	Housing: aluminium alloy Shaft: stainless steel
Operating temperature	$-40 \dots +85^\circ\text{C}$
Resistance	IEC 60068-2-6 Vibration 10 g, 10-2000 Hz IEC 60068-2-27 Shock 100 g, 6 ms
Corrosion protection	IEC 60068-2-52 Salt mist for ambient conditions C4 according to ISO 12944-2
Explosion protection	II 3 G Ex ec IIC T4 Gc (gas) II 3 D Ex tc IIIB T100°C Dc (dust) (only with option ATEX)
Connection	Terminal box 2x terminal box (with option M)
Weight approx.	4.5 kg ( $\varnothing 48$ ) 3.2 kg ( $\varnothing 75$ ) 3.6 kg ( $\varnothing 75$ with option M)

### Optional

- Redundant sensing with two terminal boxes

# HOG 161

Through hollow shaft  $\varnothing 38 \dots 75$  mm  
250...2500 pulses per revolution

## Terminal assignment

**View A** (see dimension)

Connecting terminal terminal box, radial

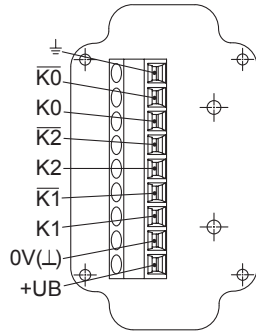

## Terminal significance

+UB	Voltage supply
0V (L)	Ground
⊥	Earth ground (housing)
K1	Output signal channel 1
$\bar{K}1$	Output signal channel 1 inverted
K2	Output signal channel 2 (offset by 90° to channel 1)
$\bar{K}2$	Output signal channel 2 inverted
K0	Zero pulse (reference signal)
$\bar{K}0$	Zero pulse inverted

## Output signals

**HTL/TTL**

At positive rotating direction (see dimension)

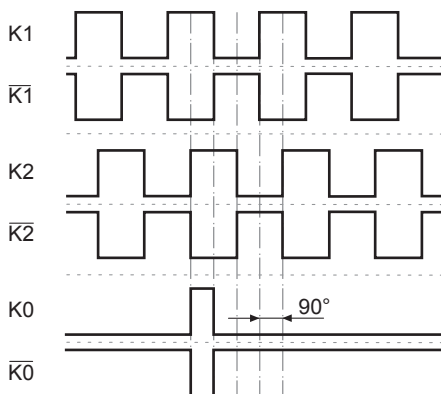

# HOG 161

Through hollow shaft  $\varnothing 38 \dots 75$  mm  
250...2500 pulses per revolution

## Dimensions

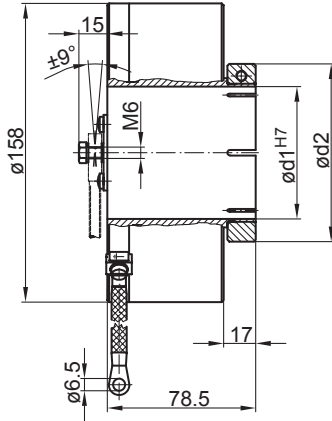

$\varnothing d1$	$\varnothing d2$
38	59
40	60.5
42	64
45	65
50	70.5
55	76
60	81
65	86.5
70	94
75	100

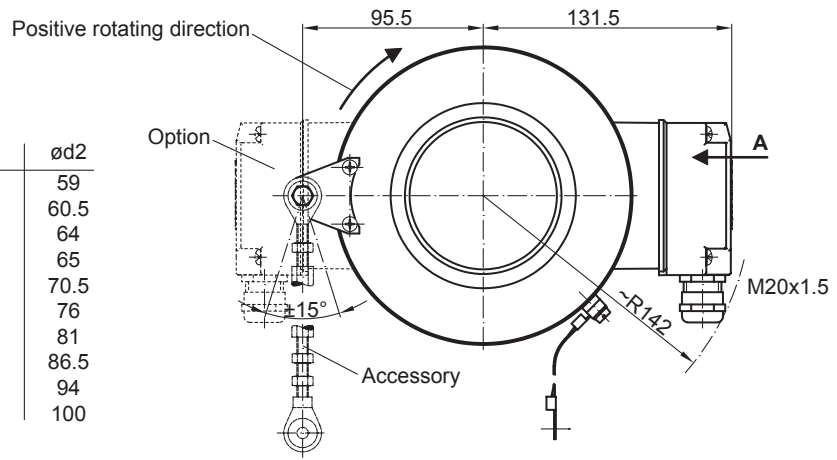

# HOG 161

 Through hollow shaft  $\varnothing 38 \dots 75$  mm  
 250...2500 pulses per revolution

## Ordering reference

	HOG161	#	##	###	###	#####
<b>Product</b>	Incremental encoder	HOG161				
<b>Redundant sensing</b>	Without redundant sensing					
	With redundant sensing		M			
<b>Output signals</b>	K1, K2			D		
	K1, K2, K0			DN		
<b>Pulse number<sup>(1)</sup></b>	250				250	
	500				500	
	512				512	
	1000				1000	
	1024				1024	
	1080				1080	
	1200				1200	
	2048				2048	
	2500				2500	
<b>Voltage supply / output stage</b>	9...30 VDC / output stage HTL					
	9...30 VDC / output stage HTL with inverted signals (for output signals DN)					I
	5 VDC / output stage TTL with inverted signals (for output signals DN)					TTL
	9...26 VDC / output stage TTL with inverted signals (for output signals DN)					R
<b>Shaft diameter</b>	Through hollow shaft $\varnothing 38$ mm					38H7
	Through hollow shaft $\varnothing 40$ mm					40H7
	Through hollow shaft $\varnothing 42$ mm					42H7
	Through hollow shaft $\varnothing 45$ mm					45H7
	Through hollow shaft $\varnothing 50$ mm					50H7
	Through hollow shaft $\varnothing 55$ mm					55H7
	Through hollow shaft $\varnothing 60$ mm					60H7
	Through hollow shaft $\varnothing 65$ mm					65H7
	Through hollow shaft $\varnothing 70$ mm					70H7
	Through hollow shaft $\varnothing 75$ mm					75H7

(1) Other pulse numbers on request.

## Accessories

### Mounting accessories

11043628	Torque arm M6, length 67...70 mm
11004078	Torque arm M6, length 120...130 mm ( $\geq 71$ mm)
11002915	Torque arm M6, length 425...460 mm ( $\geq 131$ mm)
11054917	Torque arm M6 insulated, length 67...70 mm
11072795	Torque arm M6 insulated, length 120...130 mm ( $\geq 71$ mm)
11082677	Torque arm M6 insulated, length 425...460 mm ( $\geq 131$ mm)
11077197	Mounting kit for torque arm size M6 and earthing strap