

LXG-500C

Technical Data

 Art. No.
11188976

Sensor Graph: Relative Response

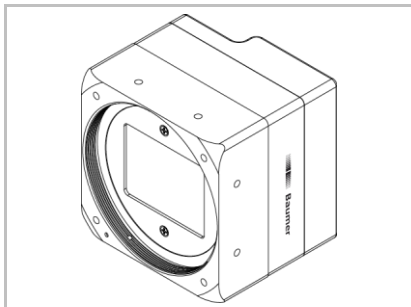
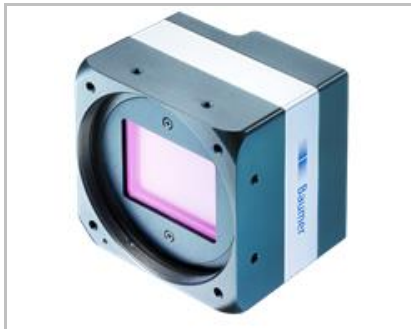
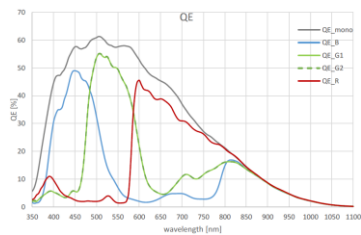

Digital Output: High Active

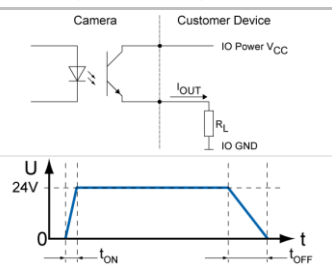

Digital Output: Low Active

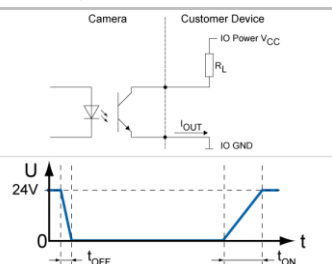

Digital Color Matrix Camera, Dual Gigabit Ethernet

Sensor Information

Model Name	CMOSIS CMV-50000
Type	35 mm progressive scan CMOS
Shutter	Global
Native Resolution	7920 x 6004 pixels
Scan Area	36.4 mm x 27.6 mm
Pixel Size	4.6 μm x 4.6 μm

Data Quality

@ 20 °C, gain = 1, exposure time = 4 msec

Readout Noise (σ)	0.2 LSB @ 8 bit (typical)
Dynamic Range	64 dB (typical)

Acquisition Formats

Image Formats	Format	Resolution	Sensor/DGigE	t_{readout}
	Full Frame	7920 x 6004	15/5 fps	65,6 msec
Pixel Formats	BayerBG8, BayerBG12, BayerBG12Packed			
Partial Scan	True Partial Scan, Region of Interest (ROI) arbitrary, up to 8 regions			

Image Pre-Processing

Analog Controls	Exposure Time (95 μsec ... 10 sec Step Size 1 μsec) Gain (0 ... 23.5 dB), Offset (0 ... 255 LSB 12 bit)
Gamma Correction	Gamma (0.1 ... 2 available if LUT is enabled)
LUT	Luminance (12 bit)
Color Models	No (Raw Bayer data only)
Color Tolerance	-
Color Processing	No (Raw Bayer data only)
Color Adjustment	White Balance (manual & one push)
Binning	-
Decimation	1 or 2 (Horizontal and Vertical)
Image Flipping	Horizontal, vertical
Defect Pixel Correction	via Defect Pixel List with up to 3000 Pixel Coordinates

Process Synchronization

Modes	Free Running, Trigger
Free Running	Continuous or Adjustable Acquisition Frame Rate (0.01 ... 3067 Hz)
Trigger Sources	Hardware, Software, ActionCommand, All or Off
Trigger Delay	0 ... 2 sec, Tracking and buffering of up to 512 triggers
Sequencer Characteristics	up to 128 sets of parameters, up to 65536 loop passes, up to 65536 repetitions of sets of parameters, up to 65536 images per trigger event
Sequencer Parameters	Exposure Time, Gain Factor, Output Line, ROI Offset x, ROI offset y
External Flash Sync	via Exposure Active $t_{\text{delay flash}} \leq 3 \mu\text{sec}$, $t_{\text{duration}} = t_{\text{exposure}} + 18 \mu\text{sec}$

Digital I/Os

Lines	Input: Line 0, Output: Line1, Line 2, Line 3
Circuit Times	Output: $t_{\text{ON}} = \text{typ. } 2 \mu\text{sec}$ $t_{\text{OFF}} = \text{typ. } 30 \mu\text{sec}$
Output Sources	Off, ExposureActive, ReadoutActive, FrameActive, TriggerReady, TriggerOverlapped, TriggerSkipped, Line 0, UserOutput{1,2,3}, Timer{1,2,3}Active, SequencerOutput{0,1,2}
Line Debouncer	Low and high signal separately selectable Debouncing Time 0 ... 5 msec, Step Size: 1 μsec

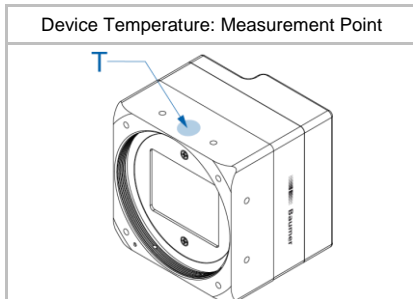
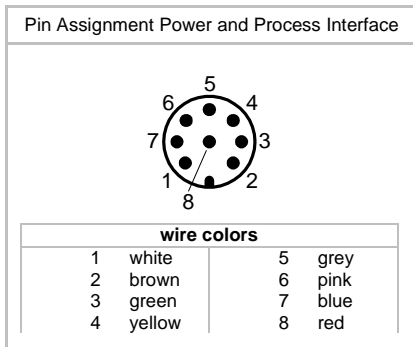
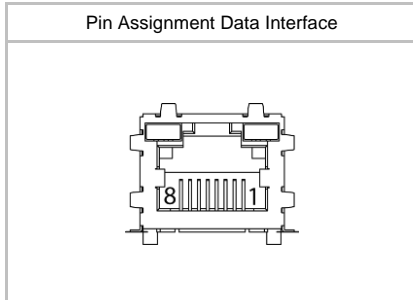
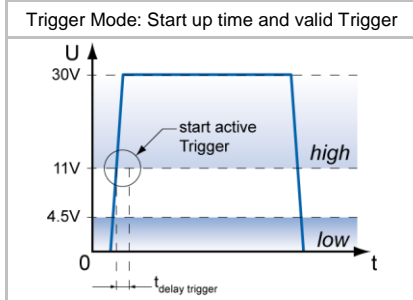
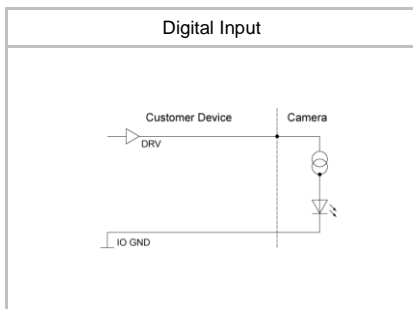

Interfaces and Connectors

Data Interface (1/2)	Gigabit Ethernet	Transfer Rate	1000 Mbits/sec
	Fast Ethernet	Transfer Rate	100 Mbits/sec
	Connector:	8P8C Modular Jack (RJ45) screw lock type	
	Pin Assignment:	1 – MX1+	5 – MX3-
		2 – MX1-	6 – MX2-
		3 – MX2+	7 – MX4+
		4 – MX3+	8 – MX4-
Power and Process Interface	Connector:	SACC-DSI-M8MS-8CON-M8-L180 SH	
	Assignment:	1 – OUT3 (line3)	5 – IO Power VCC
		2 – Power VCC	6 – OUT1 (line1)
		3 – IN1 (line0)	7 – GND
		4 – IO GND	8 – OUT2 (line2)

Mechanical Data

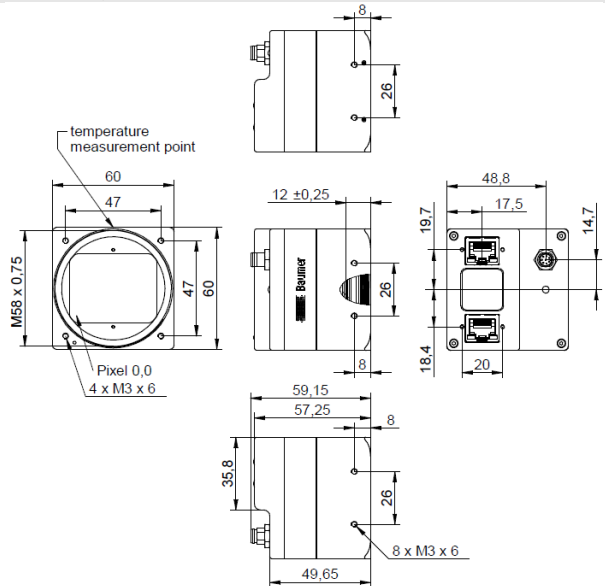
Housing	Aluminum, IP40
Dimensions	
Weight	320 g (M58-Mount), 420 g (F-Mount), 370 g (M42-Mount), 362 g (C-Mount)

Optical Data

Lens Mount	M58-Mount, via optional adapters F-/M42-/C-Mount
Optical Filter	UV/IR Cut

Electrical Data

Power Supply (ext.)	VCC:	12 ... 24 V DC ± 20%
	I:	420 ... 830 mA
Power over Ethernet	Class 0 device	
	VCC:	36 ... 57 V DC
	I:	250 mA @ 48 VDC
Power Consumption	approx.	10 W @ 24 VDC and 5 fps
	approx.	12 W @ 48 VDC (PoE) and 5 fps
Digital Input	$U_{IN(low)}$:	0.0 ... 4.5 VDC
	$U_{IN(high)}$:	11.0 ... 30.0 VDC
	I_{IN} :	6.0 ... 10 mA
	min. Impulse Length:	2.0 µsec
	Trigger Delay out of treadout:	110.0 µsec
	max. Trigger Delay during treadout:	110.0 µsec
Digital Output	U_{EXT} :	5 ... 30 V DC
	I_{OUT} :	max. 50 mA

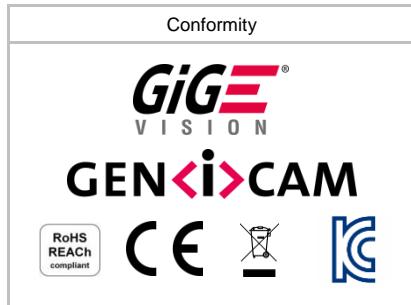
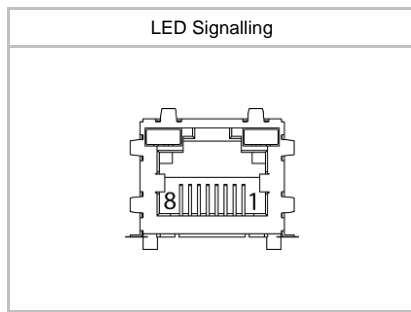

LED Signalling

Camera LED	Green on	Power on, link good
	Green blinking	Power on, no link
	Red on	Error
	Red blinking	Warning
	Yellow	Readout active
RJ45 LEDs (1/2)	Green on	Link on
	Green blinking	Link activity
	Amber on	GigE speed
	Amber blinking	100 Mb speed

Environmental Data

Storage Temperature	-10 °C ... +70 °C
Operating Temperature	+5 °C ... +66 °C @ T= Measurement Point
	or
	+10 °C ... +71 °C @ T= internal Temperature Sensor
	Ambient temperature above 28 °C requires heat dissipation
Int. Temperature Sensor	0 °C ... +85 °C accuracy: ±1 K
Humidity	10 % ... 90 % non-condensing
Conformity	RoHS, REACH, CE, EAC
KC Registration No. / Date	R-REI-BkR-LXG-500M / 25.07.2018

Network Interface Data

Network Interface	Gigabit Ethernet	1000BASE-T	1000 Mbits/sec
	Fast Ethernet	100 BASE-T	100 Mbits/sec
Link Aggregation	According to 802.3ad, static configuration		
Ethernet IP Configuration	Persistent IP, DHCP, LLA		
Packet Size	576 .. 9000 Byte, Jumbo frames supported		

GigE Vision® Features (in compliance with GigE Vision® 1.2)

Events Transmission via Asynchronous Message Channel	GigEVisionError, HeartbeatTimeout, EventLost, EventDiscarded, Line{0,1,2,3}RisingEdge, Line{0,1,2,3}FallingEdge, Action1, ExposureStart, ExposureEnd, FrameStart, FrameEnd, TriggerReady, TriggerOverlapped, TriggerSkipped, Timer{1,2,3}End, Phy{0,1}Up, Phy{0,1}Down
Frame Counter	up to 2 ³²
Payload Size	4 ... 95103572 Byte
Transmission Delay	0 .. 2 ³² -1 Ticks (1 Tick = 8 nsec)
Timestamp	64 bit
Packet Delay	0 .. 2 ³² -1 Ticks (1 Tick = 8 nsec)
Packet Resend	Resend Buffer: 408 MB (2 Images)

GeniCam™ Features (in compliance with SFNC 2.1.0)

Timer	Timer Selector: Timer 1 ... 3 TimerTriggerSource: Off, Line0, Software, Action1, TriggerSkipped ExposureStart, ExposureEnd, FrameStart, FrameEnd, TimerDelay: 0 µsec ... 2 sec, Step Size: 1 µsec TimerDuration: 10 µsec ... 2 sec, Step Size: 1 µsec
User Sets	Factory Settings: Default (read only) Freely Programmable: UserSet1, UserSet2, UserSet3 Parameters: any user definable Parameter
Acquisition Abort	Delay up to 69 msec

Vendor Specific Features

DSNU / PRNU (FPN)	Based on offset / gain per column
Correction	
Pixel Correction	Averaging filter with threshold to reduce sporadic grey value changes at random positions (salt & pepper noise)
High Dynamic Range (HDR)	NA
Burst Mode	9 full frame images with up to 15 fps

Factory Settings after Start-Up

Operation Mode	Free Running, overlapped mode
Analog Controls	Exposure Time: 4 msec, Gain: 0 dB, Offset: 0
Pixel Format	BayerBG8
Partial Scan	Off
Acquisition Frame Rate	Off
Timer	Off
Transmission Delay	Off
Defect Pixel Correction	On
FPN Correction	On
Pixel Correction	On
Digital Input	Line0, invert = false, trigger source = All
Digital Output	Line1/2/3, invert = false, line source = Off