

# PF20x-xx1xx

Flow Sensor with IO-Link



## Operating Instructions

# Table of Contents

<b>1. General</b>	<b>4</b>
1.1 Information Concerning these Instructions	4
1.2 Explanations of Symbols	4
1.3 Limitation of Liability	5
1.4 Copyrights	5
<b>2. For Your Safety</b>	<b>6</b>
2.1 Use for Intended Purpose	6
2.2 Use for Other than the Intended Purpose	7
2.3 Personnel Qualifications	7
2.4 Modification of Products	7
2.5 General Safety Precautions	8
2.6 Approvals and IP Protection	8
<b>3. Technical Data</b>	<b>9</b>
3.1 Permissible Flow Rate	11
3.2 Volumetric Flow	12
3.3 Housing Dimensions	13
3.4 Wiring Diagram	14
3.5 Accessory Products	14
3.6 Layout	15
3.7 Scope of Delivery	15
<b>4. Transport and Storage</b>	<b>16</b>
4.1 Transport	16
4.2 Storage	16
<b>5. Installation and Electrical Connection</b>	<b>17</b>
5.1 System Overview	17
5.2 Installation	17
5.3 Installation Instructions for Devices with EHEDG Certification	18
5.4 Electrical Connection	19
5.5 Diagnostics	19

<b>6. Cleaning</b> .....	<b>19</b>
<b>7. Functions Overview</b> .....	<b>20</b>
7.1 Default Settings .....	20
7.2 Function Definitions .....	20
7.2.1 Hysteresis .....	21
7.2.2 Window Width .....	21
7.2.3 Analog .....	22
7.2.4 Remote Output .....	22
7.2.5 Filter .....	24
<b>8. Settings</b> .....	<b>25</b>
<b>9. I/O-Link</b> .....	<b>26</b>
<b>10. Maintenance Instructions</b> .....	<b>26</b>
<b>11. Returns</b> .....	<b>26</b>
<b>12. Proper Disposal</b> .....	<b>27</b>
<b>13. Appendix</b> .....	<b>27</b>
13.1 EU Declaration of Conformity .....	27

# 1. General

## 1.1 Information Concerning these Instructions

- These instructions apply to the product with ID code PF20x-xx1xx.
- They make it possible to use the product safely and efficiently.
- These instructions are an integral part of the product and must be kept on hand for the entire duration of its service life.
- Local accident prevention regulations and national work safety regulations must be complied with as well.
- The product is subject to further technical development, and thus the information contained in these operating instructions may also be subject to change. The current version can be found at [www.baumer.com](http://www.baumer.com) in the product's separate download area.



### NOTE!

The operating instructions must be read carefully before using the product and must be kept on hand for later reference!

## 1.2 Explanations of Symbols

- Safety precautions and warnings are emphasized by means of symbols and attention-getting words.
- Safe use of the product is only possible if these safety precautions and warnings are adhered to.
- The safety precautions and warnings are laid out in accordance with the following principle:



### Attention-Getting Word

#### Type and Source of Danger!

Possible consequences in the event that the hazard is disregarded.

- Measures for averting the hazard.
- 

The meanings of the attention-getting words, as well as the scope of the associated hazards, are listed below.



### DANGER!

This word indicates a hazard with a high degree of risk which, if not avoided, results in death or severe injury.

---



### WARNING!

This word indicates a hazard with a medium degree of risk which, if not avoided, may result in death or severe injury.

---



### CAUTION!

This word indicates a hazard with a low degree of risk which, if not avoided, may result in minor or moderate injury.

---

**ATTENTION!**

This word draws attention to a potentially hazardous situation which, if not avoided, may result in property damage.

---

**NOTE!**

A note draws attention to useful tips and suggestions, as well as information regarding efficient, error-free use.

### 1.3 Limitation of Liability

- The product has been developed in consideration of the current state-of-the-art and applicable standards and guidelines. Subject to change without notice. A valid declaration of conformity can be accessed at [www.baumer.com](http://www.baumer.com) in the product's separate download area.
- Baumer Electric AG (hereinafter referred to as "Baumer") excludes all liability in the event of:
  - Non-compliance with the instructions
  - Use of the product for purposes other than those intended
  - Use by untrained personnel
  - Use of unapproved replacement parts
  - Unapproved modification of products
- These operating instructions do not include any guarantees from Baumer with regard to the described procedures or specific product characteristics.
- Baumer assumes no liability for printing errors or other inaccuracies contained in these operating instructions, unless Baumer was verifiably aware of such errors at the point in time at which the operating instructions were prepared.

### 1.4 Copyrights

- The contents of these instructions are protected by copyright law.
- All rights are reserved by Baumer.
- Commercial reproduction or any other commercial use of the provided content and information, in particular graphics and images, is not permitted without previous written consent from Baumer.

## 2. For Your Safety

### 2.1 Use for Intended Purpose

The product is based on the following functional principle:

#### **Flow Sensor**

The Flow Sensor measures the flow rates of oily and aqueous media in closed piping systems.

The Baumer Flow Sensor functions in accordance with the calorimetric measuring principle. This makes it possible to monitor the temperature of the medium in addition to the flow rate. The sensor detects changes to both characteristic process values and converts them into an electrical signal.

The sensor's parameters can be configured via IO-Link and adapted to the respective application. Either 2 switching outputs, or 1 switching output and 1 analog output (4 ... 20 mA / 0 ... 10 V) are available depending on settings and connection configuration.

This product can be used in the following industry sectors:

- Special machinery manufacturing
- Heavy machinery manufacturing
- Logistics
- Automotive industry
- Food industry
- Packaging industry
- Pharmaceuticals industry
- Clothing industry
- Plastics industry
- Woodworking industry
- Consumer goods industry
- Paper industry
- Electronics industry
- Glass industry
- Steel industry
- Printing industry
- Construction industry
- Chemicals industry
- Agriculture industry
- Alternative energy
- Raw materials extraction

## 2.2 Use for Other than the Intended Purpose

- Not a safety component in accordance with 2006/42/EC (Machinery Directive)
- The product is not suitable for use in potentially explosive atmospheres.
- The product may only be used with accessories supplied or approved by Baumer, or in combination with approved products. A list of approved accessories and combination products can be accessed at [www.baumer.com](http://www.baumer.com) on the product detail page.



**DANGER!**

**Risk of personal injury or property damage in case of use for other than the intended purpose!**

Use for other than the intended purpose may lead to hazardous situations.

- Instructions regarding use for intended purpose must be observed.
- 

## 2.3 Personnel Qualifications

- Suitable technical training is a prerequisite.
- In-house electronics training is required.
- Trained personnel must have uninterrupted access to the operating instructions.



**DANGER!**

**Risk of personal injury or property damage in case of incorrect initial start-up and maintenance!**

Personal injury and damage to equipment may occur.

- Adequate training and qualification of personnel.
- 

## 2.4 Modification of Products



**DANGER!**

**Risk of personal injury or property damage if the product is modified!**

Personal injury and damage to equipment may occur. Non-observance may result in loss of the CE marking and the guarantee may be rendered null and void.

- Modification of the product is impermissible.
-

## 2.5 General Safety Precautions

### NOTE!

- These instructions are an integral part of the product and must be kept on hand for the entire duration of its service life.
- In the event of possible changes, the respectively current version of the operating instructions can be accessed at [www.baumer.com](http://www.baumer.com) in the product's separate download area.
- Read the operating instructions carefully before using the product.
- Protect the sensor against contamination and mechanical influences.
- Installation and removal of the product are only permissible in pressure-free piping systems which have been allowed to cool down.



## 2.6 Approvals and IP Protection



RoHS





### 3. Technical Data

Order Number	PF20x-xx1xx
<b>Technical Data</b>	
<b>Sensor-Specific Data</b>	
<b>Flow</b>	
Flow measuring range, within a media temperature range of -25 ... 125° C	10...400 cm/s
Flow setting range	10...400 cm/s
Medium	Water
Flow measurement error	2%
Reaction time in case of abrupt temperature change	< 10 s
<b>Sensor-Specific Data</b>	
<b>Temperature</b>	
Temperature measuring range	-25...150° C
Temperature setting range	-25...150° C
Medium	Water
Temperature measurement error	± 1° C
Step response time T90	< 5 s
<b>Ambient Conditions</b>	
Ambient temperature	-25...80° C
Media temperature	-25...150° C
Storage and transport temperature	-25...80° C
Relative humidity	100%
EMC	EN 61326-1
Shock resistance per DIN EN 60068-2-27	50 g / 11 ms
Vibration resistance per DIN EN 60068-2-6	20 g (10 ... 2000 Hz)
<b>Electrical Data</b>	
Supply power	12...32 V DC
Supply power with IO-Link	18...30 V DC
Current consumption (U <sub>o</sub> = 24 V)	≤ 45 mA
Short-circuit proof	Yes
Reverse polarity and overload-proof	Yes
<b>Analog Output</b>	
	4...20 mA / 0...10 V
Output load resistance	$< \frac{(U_o - U_{min})}{20 \text{ mA}} / > 1 \text{ kOhm}$
<b>Switching Output</b>	
Voltage drop	< 1.5 V
Switching current	≤ 100 mA
Residual current	< 250 μA
Switchable to NC or NO	Yes
Interface	IO-Link

IO-Link version	1.1
Protection class	III
Operating delay time	< 10 s
<b>Mechanical Data</b>	
Setting method	I/O-Link
Housing material	Stainless steel 1.4404
Media contacting materials	Stainless steel 1.4404
Protection	IP68, IP69K
Connector type	M12 × 1, 4-pin
Process connection	See data sheet
Process connection length PCL	See data sheet
Probe length PL	See data sheet
Rod diameter	6 mm
Connection cable length	up to 30 m
<b>Output Function</b>	
Switching output switchable to flow or temperature	Yes
Analog output switchable to flow or temperature	Yes
Configurable as PNP, NPN or push-pull	Yes
Switchable to NC or NO	Yes

The following table specifies the tightening torques of the plugs and mounting options in order to assure compliant, error-free operation:

Connector Type	Tightening Torque (Nm)
M12	0.4



**CAUTION!**

- Pressure resistance specified in the data sheet always makes reference to the sensor rod.
- Amongst other factors, the system's pressure resistance is also dependent on the utilized mounting components (adapters), and is only as high as the pressure resistance of the weakest component.

### 3.1 Permissible Flow Rate

Maximum permissible flow rate depending on the temperature of the medium, pressure and probe length:

Pressure	Probe Length					Medium Temperature
	10 mm	50 mm	100 mm	150 mm	200 mm	
PN25 (25 bar)	400 cm/s	400 cm/s	400 cm/s	400 cm/s	400 cm/s	20° C
						60° C
						100° C
						150° C
PN40 (40 bar)	400 cm/s	400 cm/s	400 cm/s	400 cm/s	400 cm/s	20° C
						60° C
					350 cm/s	100° C
						150° C
PN64 (64 bar)	400 cm/s	400 cm/s	400 cm/s	400 cm/s	200 cm/s	20° C
					150 cm/s	60° C
						100° C
						150° C
PN100 (100 bar)	400 cm/s	400 cm/s	400 cm/s	400 cm/s	Not permissible	20° C
				350 cm/s		60° C
				300 cm/s		100° C
						150° C

### 3.2 Volumetric Flow

The Flow Sensor measures the flow rate at the tip of the sensor.

The pipe's inside diameter and the flow rate must be known in order to determine volumetric flow within a piping system. A volumetric flow calculator can be downloaded from [www.baumer.com](http://www.baumer.com).

Flow Rate	Nominal Size Inside dia.	DN25	DN40	DN65	DN100
		28.5 mm	43.1 mm	70.3 mm	107.1 mm
100 cm/s		33 l/min	80 l/min	220 l/min	521 l/min
150 cm/s		50 l/min	120 l/min	330 l/min	782 l/min
200 cm/s		66 l/min	160 l/min	441 l/min	1043 l/min
250 cm/s		83 l/min	200 l/min	551 l/min	1303 l/min
300 cm/s		100 l/min	239 l/min	661 l/min	1564 l/min
350 cm/s		116 l/min	279 l/min	771 l/min	1824 l/min
400 cm/s		133 l/min	319 l/min	881 l/min	2085 l/min

### 3.3 Housing Dimensions

Overall housing dimensions are included in the respective data sheet.

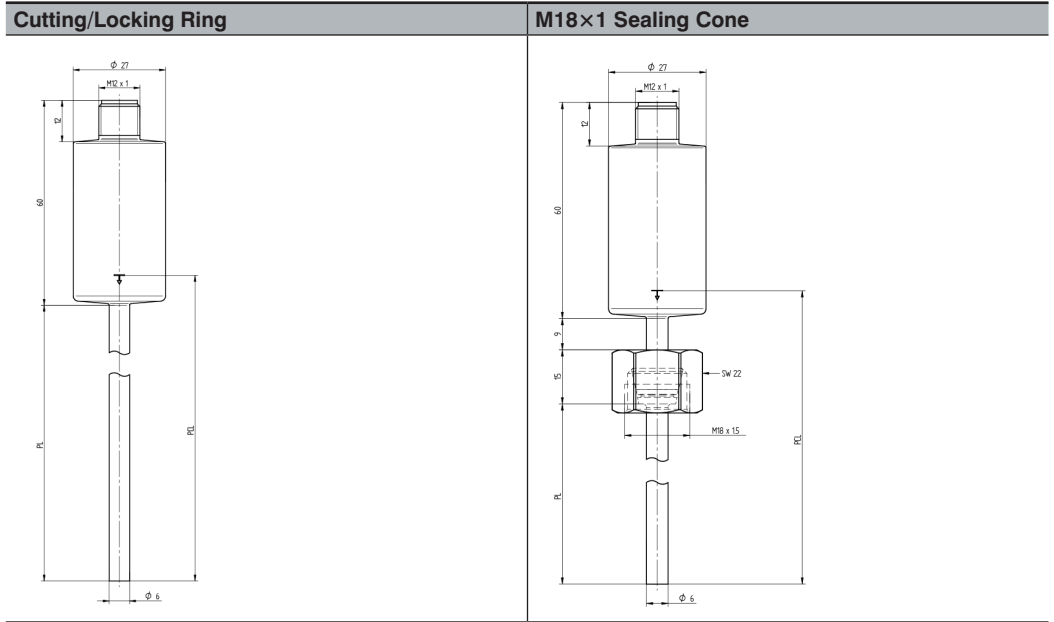

Process connection length PCL in the case of a cutting/locking ring = probe length PL + 9 mm

Process connection length PCL in the case of an M18×1 sealing cone = probe length PL + 32 mm

**NOTE!**



- There's a marking on the sensor's sleeve (see figure).
- This is a reference point (starting point) relative to the length of the process connection (see data sheet), and provides assistance in correctly positioning the sensor within the piping system.



### 3.4 Wiring Diagram

139

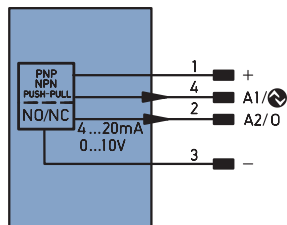

#### Legend

+	Supply Voltage +
-	Supply Voltage 0 V
~	Supply Voltage (AC Voltage)
A	Switching Output (NO)
$\bar{A}$	Switching Output (NC)
V	Contamination/Error Output (NO)
$\bar{V}$	Contamination/Error Output (NC)
E	Input (analog or digital)
T	Teach Input
Z	Time Delay (activation)
S	Shielding
RxD	Interface Receive Path
TxD	Interface Send Path
RDY	Ready
GND	Ground
CL	Clock
E/A	Output/Input programmable
	IO-Link
PoE	Power over Ethernet
IN	Safety Input
OSSD	Safety Output
Signal	Signal Output
BL_D+/-	Ethernet Gigabit bidirect. data line (A-D)
ENaRS422	Encoder 0-pulse 0-0 (TTL)

PT	Platinum measuring resistor
nc	not connected
U	Test Input
$\bar{U}$	Test Input inverted
W	Trigger Input
W-	Ground for the Trigger Input
O	Analog Output
O-	Ground for the Analog Output
BZ	Block Discharge
AMV	Valve Output
a	Valve Control Output +
b	Valve Control Output 0 V
SY	Synchronization
SY-	Ground for the Synchronization
E+	Receiver-Line
S+	Emitter-Line
$\pm$	Grounding
SnR	Switching Distance Reduction
Rx +/-	Ethernet Receive Path
Tx +/-	Ethernet Send Path
BuS	Interfaces-Bus A(+)/B(-)
La	Emitted Light disengageable
Mag	Magnet activation
RES	Input confirmation
EDM	Contactur Monitoring

ENaRS422	Encoder A/ $\bar{A}$ (TTL)
ENaRS422	Encoder B/ $\bar{B}$ (TTL)
ENa	Encoder A
ENb	Encoder B
AMIN	Digital output MIN
AMAX	Digital output MAX
AOK	Digital output OK
SY In	Synchronization In
SY OUT	Synchronization OUT
GLT	Brightness output
M	Maintenance
rSV	reserved
Wire Colors according to IEC 60757	
BK	Black
BN	Brown
RD	Red
OG	Orange
YE	Yellow
GN	Green
BU	Blue
VT	Violet
GY	Grey
WH	White
PK	Pink
GNYE	Green/Yellow

### 3.5 Accessory Products

Baumer can provide you with suitable connection technology for your product. The products can be found at [www.baumer.com](http://www.baumer.com).

### 3.6 Layout

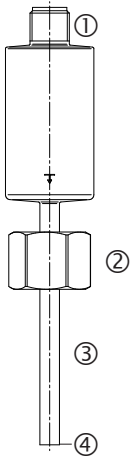

- ① = plug connector
- ② = process connection
- ③ = sensor rod
- ④ = measuring probe

### 3.7 Scope of Delivery

- PF20x-xx1xx Flow Sensor
- Quick-start guide

## 4. Transport and Storage

### 4.1 Transport

Upon receipt of shipment, inspect the goods for damage in transit. In the case of damage, conditionally accept the package and notify the manufacturer of the damage. Then return the device, making reference to damage in transit.

### 4.2 Storage

The following points must be taken into condition with regard to storage:

- Do not store the product outdoors.
- Store the product in a dry, dust-free place.
- Protect the product against mechanical impacts.



**ATTENTION!**

**Risk of property damage in case of improper storage!**

The product may be damaged.

- Comply with storage instructions.
-



## 5. Installation and Electrical Connection

### 5.1 System Overview

Matching products for your device can be found at [www.baumer.com](http://www.baumer.com).

### 5.2 Installation

- Protect the product from contamination during installation.
- Observe all applicable electrical and mechanical regulations, standards, and safety rules.
- Protect the product against mechanical influences.
- Make sure that the sensor is mounted in a mechanically secure fashion.
- Specified torque values must be complied with (see “3. Technical Data” on page 9).

#### Mounting

Conditions for correct detection of the flow rate:

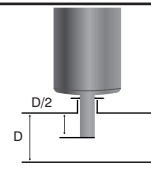
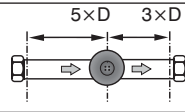
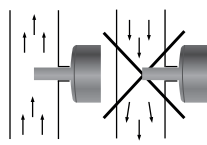
<p>In order to correctly detect the flow rate, the tip of the sensor is positioned ideally in the middle of the pipe.</p>	
<p>Adequate distance from pipe bends and points at which cross-sections change must be maintained in order to correctly detect the flow rate.</p>	
<p>Install sensors in closed systems and riser pipes because detection of the flow rate is faulty in pipes which are open at the bottom.</p>	



#### ATTENTION!

##### Risk of property damage in case of improper installation!

- The product may be damaged.
- Comply with installation instructions.



#### CAUTION!

##### Risk of personal injury or property damage during installation!

- Personal injury and damage to the product may occur.
- Ensure a safe installation environment.

### 5.3 Installation Instructions for Devices with EHEDG Certification

Sensors with an “EHEDG Certified” label (see technical data for the respective sensor) are suitable for CIP applications and do not have to be removed for cleaning. The following instructions must be adhered to in order to comply with EHEDG certification:

- The product may only be mounted to suitable equipment which complies with EHEDG guidelines.
- The product must be installed such that there is no dead space.
- The equipment must be set up such that the system can subsequently still be entirely emptied.
- If mounted to a T-fitting, the necking may not be longer than the inside diameter of it minus the sensor probe diameter:  $L < (D - d)$ .

- Example:

Diameter necking  $D = 20$  mm

Diameter sensor probe  $d = 6$  mm

Length  $L < 20 - 6$  mm  $\rightarrow L < 14$  mm

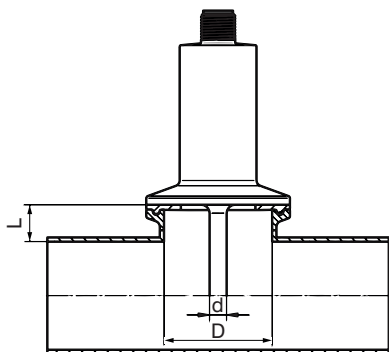

- If the product is mounted to a tank, the cleaning device must be installed so that it directly flushes the connection/dead space.
- Only suitable seals may be used which comply with EHEDG guidelines. In particular in the case of fittings in accordance with DIN 11851 (dairy pipe fittings) and DIN 32676 (clamp connections), the seal must be chosen according to the EHEDG Position Paper on easy cleanable pipe couplings and process connections. Suitable seals can be purchased from a specialist retailer.
- Varivent connection:
  - Restriction type F: Installation only permitted in tank mounting flanges
  - Type N: Installation in tank mounting flanges and pipelines

## 5.4 Electrical Connection

- Connect the sensor to 12 to 32 V DC (see “3.4 Wiring Diagram” on page 14).
- When operated with IO-Link:
  - An IO-Link master with class A port must be used because pin 5 is not connected in the case of a class A port.
  - In the case of excessive interference, a shielded cable should be used.



---

**DANGER!****Risk of personal injury or property damage due to electric current!**

Voltage conducting parts may cause personal injury or damage to equipment.

- The electric device may only be connected by appropriately qualified personnel.
- 

## 5.5 Diagnostics

Required action in case of fault:

**NOTE!**

- Shut down the machine.
- If the error cannot be eliminated, please contact Baumer’s support department.
- Do not operate in case of indeterminate malfunctioning.
- The machine must be shut down if the error cannot be unequivocally clarified or reliably eliminated.



---

**DANGER!****Risk of personal injury or property damage in case of non-compliance!**

The system’s safety function is disabled. Personal injury and damage to equipment.

- Required action as specified in case of fault.
- 

## 6. Cleaning

- Sensors with an “EHEDG Certified” label are suitable for CIP applications and do not have to be removed for cleaning.
- Permissible ambient temperature and degree of protection must be observed when cleaning from the outside.
- When selecting a cleaning agent, the degree of resistance demonstrated by the materials must be taken into consideration. A resistance table can be downloaded from [www.baumer.com](http://www.baumer.com).

## 7. Functions Overview

### 7.1 Default Settings

		PF20x-xx1xx
Function A1	Output	Switching output
	Measurement, physical quantity	Flow
	Output function	PNP NO
	Switching point 1	2 m/s
	Switching point 2	1.5 m/s
Function A2	Output	Analog output
	Measurement, physical quantity	Flow
	Output function	Current: 4 ... 20 mA
	Initial value, analog output	0 m/s
	Final value, analog output	4 m/s

### 7.2 Function Definitions

- All functions are configured via the IO-Link interface.
- Refer to the interface protocol concerning parameters configuration (available at [www.baumer.com](http://www.baumer.com) on the product detail page).

Designation	Function	Page
Hysteresis	Adjust switching hysteresis	<a href="#">Page 21</a>
Window width	Set window width	<a href="#">Page 21</a>
Analog	Scale analog output	<a href="#">Page 22</a>
Remote output	Output for external control signals	<a href="#">Page 22</a>
Filter	Set the filter	<a href="#">Page 24</a>

### 7.2.1 Hysteresis

- Depending on the settings selected for switching points 1 and 2, the sensor's switching performance can be adjusted to the application.

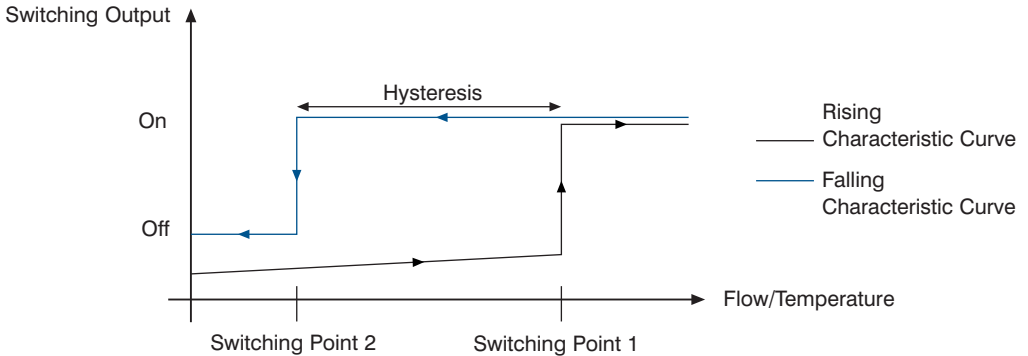

### 7.2.2 Window Width

- If switching points 1 and 2 are reversed, a window for actual and target value comparison can be set up with just one switching output.
- Refer to the interface protocol concerning parameters configuration (available at [www.baumer.com](http://www.baumer.com) on the product detail page).

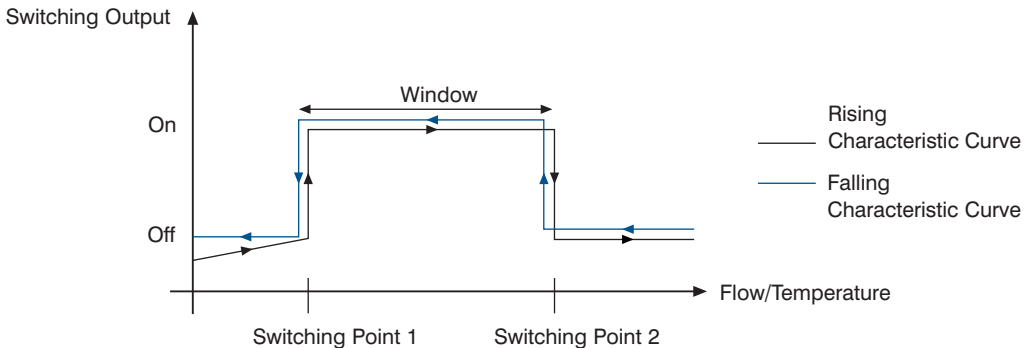

Hysteresis amounts to 5 cm/s for flow and 0.5° C for temperature.

### 7.2.3 Analog

- Allocation of the analog starting point of 4 mA/0 V and the analog end point of 20 mA/10 V to the measuring range is freely selectable.

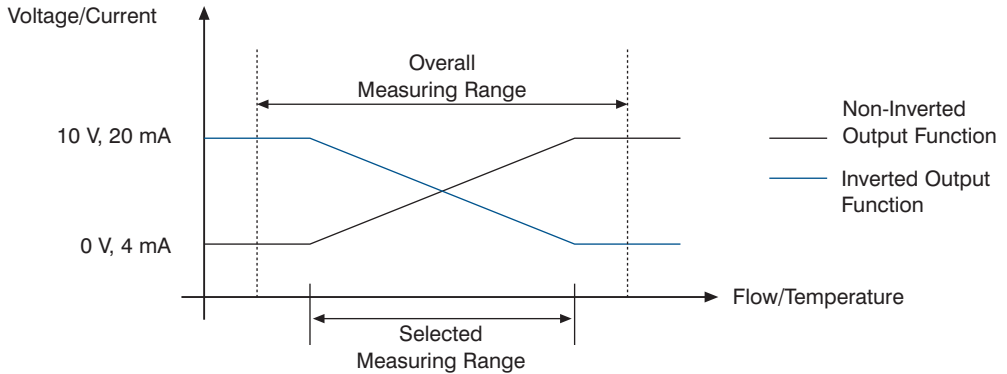

### 7.2.4 Remote Output

#### General Explanation

- If the sensor is operated with IO-Link (pin 4), the free output (pin 2) can be used for control signals.
- The output can be configured as a switching output or as an analog output.
- In this way, the need for an additional output at the controller is eliminated and external components can be switched by the sensor (e.g. a lamp) or actuated by means of an analog control signal (U/I) (e.g. a valve).

#### Prerequisite

- The sensor must be operated via IO-Link.

#### Procedure

- See figures 1 and 2 below with regard to wiring and connection.
- Setup via IO-Link in order to specify whether pin 2 is a remote analog output (U/I) or a remote switching output.
- The controller transmits the signal intended for the external component via IO-Link.
- The sensor transmits the signal to pin 2 (analog or switching output) and forwards it.
- The external component is controlled by the sensor's output. No additional output is required at the controller.
- The analog output can be scaled from 0 ... 1000 (0 = 4 mA / 0 V, 1000 = 20 mA / 10 V).

## Wiring

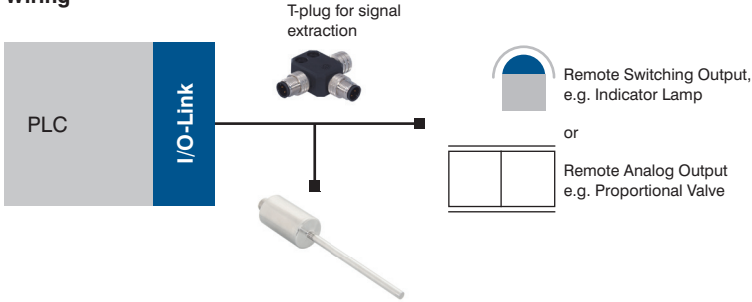

Figure 1: Wiring With Remote Output Function

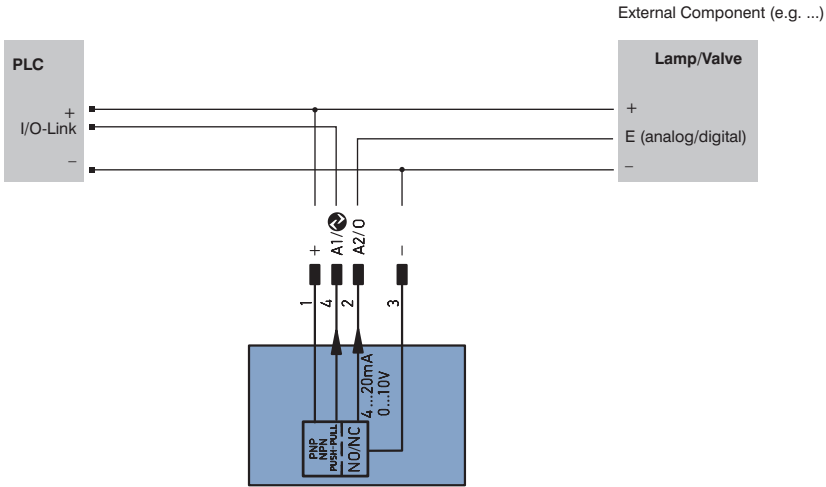

Figure 2: Wiring

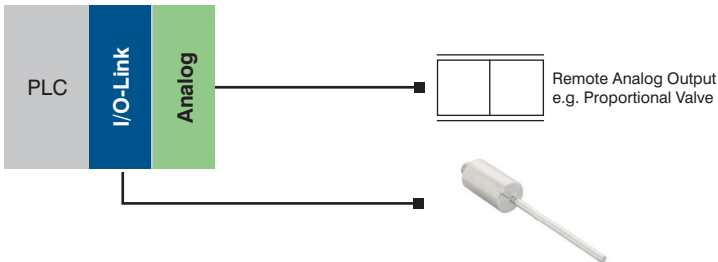

Figure 3: Wiring Without Remote Output Function

## 7.2.5 Filter

- The filter represents the number of values used by the sensor to generate a mean value.
- The higher the filter number, the longer the sensor's step response time T90 when the measured values change.
- The filter only affects flow measurement.
- Temperature is measured without filter. Temperature measurement data are reported cyclically every 3.6 seconds via IO-Link.

Filter	Number of Measured Values	Step Response Time T90
0	1	1.8 s
1	2	7.2 s
2 (default)	4	16 s
3	8	32 s
4)	16	65 s (1 min)
5	32	131 s (2 min)
6	64	265 s (4 min)
7	128	529 s (9 min)
8	256	1060 s (18 min)
9	512	2120 s (35 min)
10	1024	4242 s (71 min)



## 8. Settings

Parameters adjustable via the IO-Link interface:

<b>Sensor Settings</b>	
Temperature unit of measure	°C °F
Switching output function	PNP NPN Push-pull
Analog output function	4 ... 20 mA 0 ... 10 V
Function, output 1	Flow rate switching output Temperature switching output
Function, output 2	Flow rate switching output Temperature switching output Analog flow rate output Analog temperature output Remote switching output Remote analog output
Filter	0 ... 10 where 0 = filter off
<b>Output Settings</b>	
<b>Output 1 (switching output)</b>	
Switching point 1	Flow or temperature
Switching point 2	Flow or temperature
Switching function	NO NC
<b>Output 2 (switching output)</b>	
– only visible if switching output has been selected for “Function, output 2” –	
Switching point 1	Flow or temperature
Switching point 2	Flow or temperature
Switching function	NO NC
<b>Output 2 (analog output)</b>	
– only visible is analog output has been selected for “Function, output 2” –	
Starting temperature (value for 4 mA / 0 V)	Flow or temperature
End temperature (value for 20 mA / 10 V)	Flow or temperature
Analog output	Current: 4 ... 20 mA Voltage 0 ... 10 V
<b>Output 2 (remote switching output)</b>	
– only visible if remote switching output has been selected for “Function, output 2” –	
Output	Open/closed
<b>Output 2 (remote analog output)</b>	
– only visible if remote analog output has been selected for “Function, output 2” –	
Analog value	0 to 1000

Sensor Restrictions	
Write access disabling	Yes No
Data storage disabling	Yes No
Sensor Commands	
Standard	Restore default settings

#### Process data available via IO-Link interface:

- Status of the switching outputs
- Warning regarding unstable flow signal
- Flow rate
- Media temperature

## 9. I/O-Link

Process and parameters data can be found at [www.baumer.com](http://www.baumer.com) in the product's separate download area.

## 10. Maintenance Instructions

### NOTE!



- This Baumer sensor is maintenance-free.
- Cleaning and inspection of the plug connections at regular intervals is advisable.
- Do not clean the sensor with solvents or cleansers which could damage the product.
- The product must be protected against contamination during initial start-up.
- Contamination which adheres to the measuring probe distorts the measured value for flow rate.

## 11. Returns

Due to legal regulations and for the protection of employees, Baumer Electric AG requires a signed declaration of decontamination before your order can be processed. The corresponding form is available at [www.baumer.com](http://www.baumer.com).

## 12. Proper Disposal

Baumer Electric AG does not accept the return of unusable or irreparable products. Respectively valid national waste disposal regulations apply to product disposal.

## 13. Appendix

### 13.1 EU Declaration of Conformity

The EU declaration of conformity can be found on our website at [www.baumer.com](http://www.baumer.com) in the product's separate download area.