

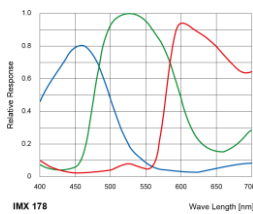

Sensor Graph: Relative Response

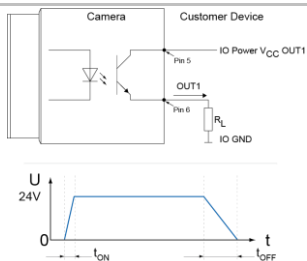

Digital Output: High Active



Digital Output: Low Active

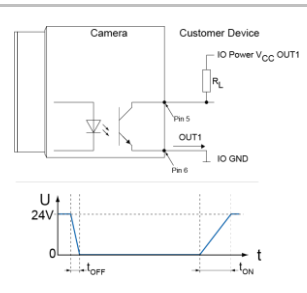

¹⁾ Sensor readout, different from pixel format

²⁾ depends on the used interface



Device Information

Model Name	VCXG.2-65C.R
Vendor Name	Baumer

Sensor Information

Sensor Name	Sony IMX178
Type	1/1.8" progressive scan CMOS
Shutter	Rolling Shutter, Global Reset Shutter
Resolution	3072 x 2048 pixels
Scan Area	7.37 mm x 4.91 mm
Pixel Size	2.4 μm x 2.4 μm

Data Quality

@ 20 °C, gain = 1, exposure time = 4 msec

Dark Noise (σ)	2.8 e- typical
Saturation	14500 e- typical
Dynamic Range	72 dB typical
SNR	42 dB typical
Quantum efficiency η	58% @ 465 nm, 63% @ 536 nm, 47% @ 631 nm typical

Acquisition

Resolution	3072 px x 2048 px		
Interface Frame Rate (depends on used interface performance)	Format	Resolution	max. Frame Rate (@ Trigger Mode) ²⁾
	Full Frame	3072 x 2048	19 fps
	Binning 2x2	1536 x 1024	29 fps
	Binning 2x1	1536 x 2048	29 fps
	Binning 1x2	3072 x 1024	29 fps
Acquisition Frame Rate ¹⁾ (Burst Mode)	29 fps t _{readout} = 33.8 msec (max. Res. Full Frame) @ 10 bit		
	29 fps t _{readout} = 33.7 msec (max. Res. Full Frame) @ 12 bit		

Pixel Formats	BayerRG8, BayerRG10, BayerRG12, BayerRG12p Mono8, Mono10, Mono12, Mono12p, RGB8, BGR8
---------------	--

Partial Scan	True Partial Scan with increasing Frame Rate on Y direction, Region of Interest (ROI) arbitrary Width: minimum 32, increment 32 Height: minimum 4, increment 4
--------------	--

Adjustable Acquisition Frame Rate	Off or 0.98 ... 65535 Hz
Acquisition Mode	Continuous, Single Frame and Multi Frame
Acquisition Status	AcquisitionActive, AcquisitionTrigger Wait
Exposure Mode	Timed
Shutter Mode	Rolling, Global Reset
Readout Mode	not available

Image Pre-Processing

Analog Controls	Exposure Time (34 μsec ... 60 sec Step Size 1 μsec) Gain (0...48 dB), Offset (0 ... 255 LSB 12 bit)
Auto Function	ExposureAuto and GainAuto with BrightnessAutoPriority based on BrightnessAuto ROI BalanceWhiteAuto and ColorTransformationAuto based on BalanceWhiteAuto ROI
LUT	Luminance (12 bit)
Color Models	Mono, Raw Bayer, RGB and BGR
Color Processing	Integrated color processor for high quality color calculation
Color Adjustment	Manual White Balance Automatic White Balance (Once or Continuous) based on Region of Interest (ROI)

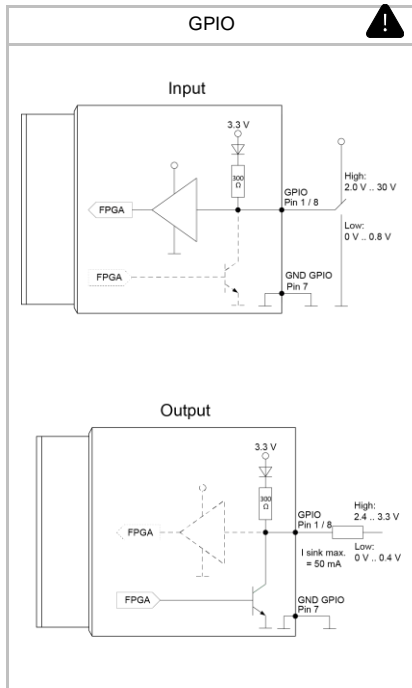
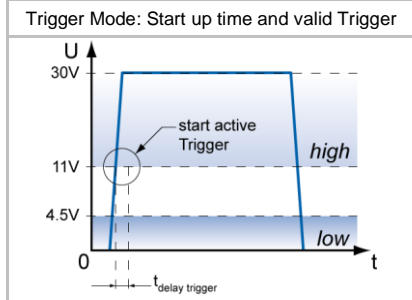
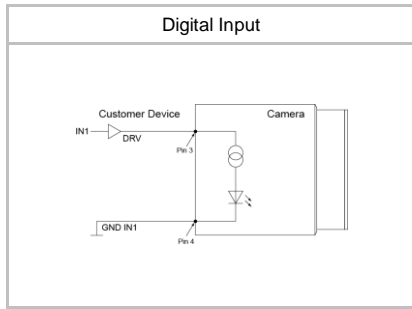

Image Pre-Processing

Color Enhancement	Color Transformation to sRGB color space by optimized Matrix for 3000 K, 5000 K, 6500 K and 9500 K Lightsource or User defined Matrix
Color Tolerance	-
Binning Horizontal	1 or 2
Binning Vertical	1 or 2
Defect Pixel Correction	yes, static DPC: Defect Pixel List with up to 512 Pixel Coordinates
Image Flipping	no
Fix Pattern Noise Correction	-

Process Synchronization

Trigger Mode	Off (Free Running), On (Trigger)
Trigger Overlap Type	Trigger Mode On: Off Trigger Mode Off: Not available
Trigger Sources	Hardware (Line0, 1, 2), Software, Counter 1, 2 End, Action CMD (Action 1), All or Off max. Trigger Delay out of t _{treadout} : ¹⁾ 1291 µsec / 969 µsec @ 10 bit (Rolling / Global Reset) 1295 µsec / 971 µsec @ 12 bit (Rolling / Global Reset) max. Trigger Delay during t _{treadout} : ¹⁾
Trigger Delay	0 ... 2 sec, Tracking and buffering of up to 256 triggers via Exposure Active
External Flash Sync	t _{delay flash} ≤ 3 µsec, t _{duration} = t _{exposure}
Encoder Function	yes, via Counter and Trigger Source
PTP Function	-

Digital I/Os

Lines	Input: Line 0, Output: Line3, GPIO: Line 1, Line 2
Line Sources (Output)	Off, ExposureActive, Timer1, ReadoutActive, UserOutput 1-3 and TriggerReady
Line Debouncer (Input)	Low and high signal separately selectable Debouncing Time 0 ... 5 msec, Step Size: 1 µsec

Memory

Image Buffer	36 MB
Non-volatile Memory	4 Images (Trigger Mode) / 1 Image (Free Running Mode) 128 kb

Network Interface Data

Interface	Gigabit Ethernet 1000BASE-T 1000 Mbits/sec Fast Ethernet 100 BASE-T 100 Mbits/sec
Ethernet IP Configuration	Persistent IP, DHCP, LLA
Packet Size	576 ... 9000 Byte, Jumbo Frames supported

GigE Vision® Features

Events	DeviceTemperatureStatusChanged, EventLost, ExposureEnd, ExposureStart, FrameEnd, FrameStart, FrameTransferSkipped, GigEVisionError, GigEVisionHeartbeatTimeout, PrimaryApplicationSwitch, Line0..2 FallingEdge, Line0..2 RisingEdge, TransferBufferFull, TransferBufferReady, TriggerOverlapped, TriggerReady, TriggerSkipped
Transmission via Asynchronous Message Channel	
Action CMD	yes, Action 1 for Trigger
Frame Counter	up to 2 ³²
Payload Size	0 ... 18874580 Byte
Timestamp	64 bit, resolution in nsec, increment = 10
Packet Delay	0 ... 2 ³² - 1 nsec
Packet Resend	Resend Buffer: 72 MB (4 Images)
GigE Vision	v2.0

¹⁾ Sensor readout, different from pixel format

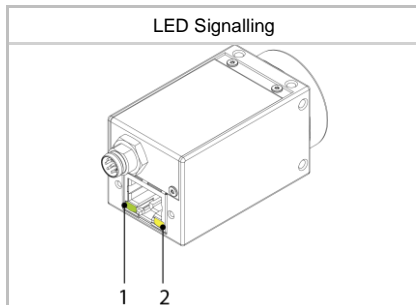
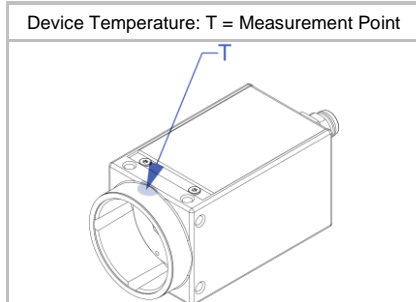
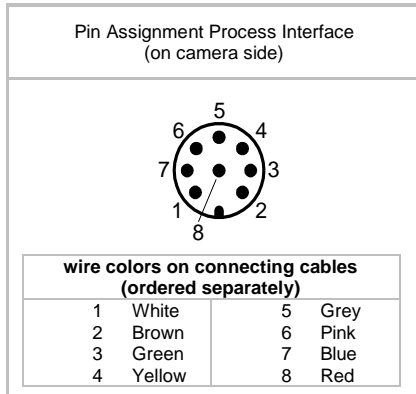
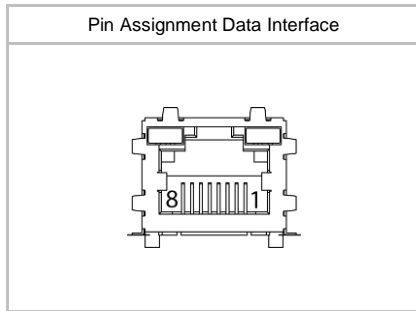

Interfaces and Connectors

Data and Power Interface	Gigabit Ethernet	Transfer Rate	1000 Mbits/sec
	Fast Ethernet	Transfer Rate	100 Mbits/sec
	Connector:	8P8C Modular Jack (RJ45), screwable TYPE090 (according to GigE Vision Mechanical Supplement)	
	Assignment:	1 - MX1+	2 - MX1-
		3 - MX2+	4 - MX3+
		5 - MX3-	6 - MX2-
		7 - MX4+	8 - MX4-

Process Interface	Connector:	M8/8-pin (SACC-DSI-M8MS-8CON-M8-L180)
	Assignment:	1 - GPIO (Line2) 2 - Power Vcc 3 - IN1 (Line0) 4 - GND IN1 5 - Power VCC OUT 6 - OUT1 (Line3) 7 - GND (Power, GPIO) 8 - GPIO (Line1)

Caution



* Note GPIOs: Ground loops are to be avoided and can lead to destruction of the device.

Optical Data

Lens Mount	C-Mount
Optical Filter	IR cut filter

Mechanical Data

Housing	Zinc die casting, baked varnish
Protection Class	IP40 (with mounted lens and GigE cable)
Weight	90 g

Dimensions

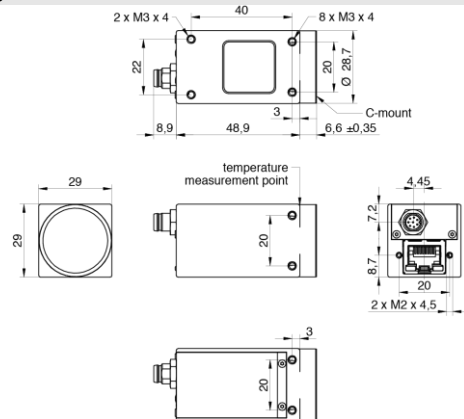

Additional Cooling Pipe	no
-------------------------	----

Environmental Data

Storage Temperature	-20 °C ... + 70 °C
Operating Temperature	0 °C ... +65 °C @ T = Measurement Point or 0 °C ... +75 °C @ internal Temperature Sensor Note: Ambient temperature above 37 °C requires heat dissipation measures.
Int. Temperature Sensor	yes, InHouse: step size 0.0625 °C, accuracy ±0.5 °C (typ) 0 °C ... +85 °C
Humidity	10 % ... 90 % non-condensing

¹⁾ the maximum temperature for Sony sensor characteristics (sensor performance) are guaranteed up to 54 °C @ Measurement Point or up to 60 °C @ internal temperature sensor

LED Signalling

LED	LED 1	Yellow static - Error Yellow flash - TX active
	LED 2	Green static - Link ON Green flash - RX active

Electrical Data

Power Supply (ext.)	VCC: 12 ... 24 V DC \pm 20% I: 111 ... 224 mA
Power over Ethernet	Class 1 device VCC: 36 ... 57 V DC I: 68 mA @ 48 VDC
Power Consumption	approx. 2.7 W @ 12 VDC and 19 fps approx. 3.2 W @ 48 VDC (PoE) and 19 fps (Factory Setting "Default")
Digital Input	Optocoupler $U_{IN(low)}$: 0.0 ... 4.5 VDC $U_{IN(high)}$: 11.0 ... 30.0 VDC I_{IN} : 3.0 ... 10.0 mA min. Impulse Length: 2.0 μ sec
Digital Output	Optocoupler U_{EXT} : 5 ... 30 V DC I_{OUT} : max. 50 mA t_{ON} = typ. 3 μ sec t_{OFF} = typ. 40 μ sec
GPIO	direct, without optocoupler
GPIO used as Input:	$U_{IN(low)}$: 0.0 ... 0.8 VDC $U_{IN(high)}$: 2.0 ... 30.0 VDC min. Impulse Length: 2.0 μ sec
GPIO used as Output:	$U_{Out(low)}$: 0.0 ... 0.4 VDC ($I_{sink\ max}$: 50 mA) $U_{Out(high)}$: 2.4 ... 3.3VDC (I_{max} : 1 mA)
Caution 	* The General Purpose I/Os (GPIOs) are not potential-free and do not have an overrun cut-off. Incorrect wiring (overvoltage, undervoltage or voltage reversal) can lead to defects in the electronic system. Ground loops are to be avoided and can lead to destruction of the device.

Conformity

Conformity	CE, RoHS, REACH, UL Recognized, KC
KC Registration No. / Date	R-R-BkR-VCXG2-65MR / 26.02.2024
MTBF	58 years @ T = 45 °C / 37 years @ T = 60 °C T = Measurement Point

GeniCam™ Features

Short Exposure Range	-
Timer	Timer Selector: Timer 1 TimerTriggerSource: Line0, SoftwareTrigger, ExposureStart, ExposureEnd, FrameTransferSkipped, TriggerSkipped, Off TimerDelay: 0 μ sec ... 2 sec, Step Size: 1 μ sec TimerDuration: 4 μ sec ... 2 sec, Step Size: 1 μ sec
Counter	Counter Selector: Counter 1, Counter 2 CounterValue: 0 ... 65535 Counter Event Source: Counter1End or Counter2End, ExposureActive, FrameTransferSkipped, FrameTrigger, TriggerSkipped, Line0..2 and Off Counter Reset Source: Counter1End, Counter2End, Line0..2 and Off

GenICam™ Features

Sequencer	no
User Sets	Factory Settings: UserSet0 (read only) Freely Programmable: UserSet1, UserSet2, UserSet3 Parameters: any user definable Parameter
Acquisition Abort	Delay up to 33.8 msec
Chunk Data	yes, Chunk Selector: Binning, BlackLevel, CounterValue, DeviceTemperature, ExposureTime, FrameID, Gain, Height, Image, ImageControl, LineStatusAll, OffsetX, OffsetY, PixelFormat, , Timestamp, Width
Device Temperature	InHouse Event generation, if temperature status changed from Normal to High, High to Exceeded and Exceeded to Normal Exceeded (no image transfer) = max. internal temperature sensor + 1 °C
Device Link Throughput Limit	yes, up to max. Device Link Speed
Custom Data	yes, 128 Byte with CustomDataKonfiguration Mode
Optical Black Pixel Area	-
Black Level Auto Adjust	-
Calibration Data	yes, camera calibration values can stored: CalibrationMatrix, CalibrationMatrixNew, CalibrationFocalLenght, CalibrationAngularAperture, GeometryDistortionValue: k1, k2, p1, p2, k3, CalibrationVector: tvec, rvec and CalibrationDataVersion
Device Indicator Mode (LED)	Active (Default), Inactive or ErrorStatus
SFNC Version	2.4.0

Factory Settings after Start-Up

Ethernet IP Configuration	DHCP, LLA
Trigger Mode	Off (Free Running)
Analog Controls	Exposure Time: 4 msec, Gain: 0 dB, Offset: 0
Pixel Format	BayerRG8
Partial Scan	Off
Acquisition Frame Rate	Off
Timer/Counter/Sequencer	Off
Defect Pixel Correction	On
Fixed Pattern Noise Correction	-
Optical Black Pixel Area	-
Black Level Auto Adjust	-
Digital Input	Line0, invert = false
Digital Output	Line3, invert = false, line source = Off
GPIO 1/2	Line1, Line2, invert = false, LineMode = Input
TriggerSource	All

Partial Scan @ FullFrame, min Exposure, Mono8 (monochrome camera) or BayerRG8 (color camera)

	Resolution	max. fps acquisition	max. fps interface ²⁾
Full HD	1920 x 1080	53	53
SXGA	1280 x 1024	56	56
HD720	1280 x 720	76	76
XGA	1024 x 768	72	72
SVGA	800 x 600	89	89
VGA	640 x 480	107	107
CIF	352 x 288	147	147
QVGA	320 x 240	147	147
QCIF	176 x 144	147	147
Full HD	1920 x 1080	53	53
SXGA	1280 x 1024	56	56
HD720	1280 x 720	76	76
XGA	1024 x 768	72	72
SVGA	800 x 600	89	89
VGA	640 x 480	107	107
CIF	352 x 288	147	147
QVGA	320 x 240	147	147
QCIF	176 x 144	147	147

²⁾ depends on the used interface