

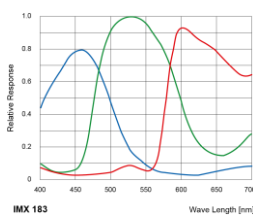

Sensor Graph: Relative Response

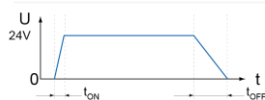

Digital Output: High Active

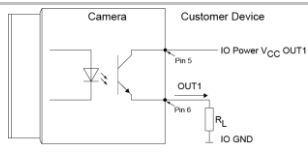

Digital Output: Low Active

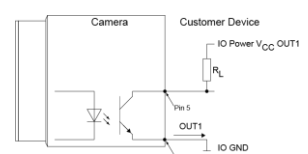

## Device Information

Model Name	VCXG.2-13M
Vendor Name	Baumer

## Sensor Information

Sensor Name	ON Semiconductor PYTHON1300
Type	1/2" progressive scan CMOS
Shutter	Global Shutter
Resolution	1280 x 1024 pixels
Scan Area	6.14 mm x 4.91 mm
Pixel Size	4.8 μm x 4.8 μm

## Data Quality

@ 20 °C, gain = 1, exposure time = 4 msec

Dark Noise ( $\sigma$ )	10 e- typical
Saturation	7300 e- typical
Dynamic Range	57 dB typical
SNR	39 dB typical
Quantum efficiency $\eta$	56% @ 536 nm typical

## Acquisition

Resolution	1280 px x 1024 px		
Interface Frame Rate (depends on used interface performance)	Format	Resolution	max. Frame Rate (@ Trigger Mode) <sup>2)</sup>
	Full Frame	1280 x 1024	94 fps
	Binning 2x2	640 x 512	148 fps
	Binning 2x1	640 x 1024	148 fps
	Binning 1x2	1280 x 512	148 fps

Acquisition Frame Rate<sup>1)</sup> 148 fps |  $t_{\text{readout}} = 6.74 \text{ msec}$  (max. Res. Full Frame) @ 10 bit (Burst Mode)

Pixel Formats	Mono8, Mono10
Partial Scan	True Partial Scan with increasing Frame Rate on X and Y direction, Region of Interest (ROI) arbitrary Width: minimum 24, increment 8 Height: minimum 1, increment 1

Adjustable Acquisition Frame Rate	Off or 0,01 ... 9174 Hz
Acquisition Mode	Continuous, Single Frame and Multi Frame
Acquisition Status	AcquisitionActive, AcquisitionTrigger Wait
Exposure Mode	Timed
Shutter Mode	Global
Readout Mode	Sequential

## Image Pre-Processing

Analog Controls	Exposure Time (20 μsec ... 1 sec   Step Size 1 μsec) Gain (0...18 dB), Offset (0 ... 63 LSB   10 bit)
Auto Function	ExposureAuto and GainAuto with BrightnessAutoPriority based on BrightnessAuto ROI
LUT	Luminance (12 bit)
Color Models	Mono
Color Processing	-
Color Adjustment	-

<sup>1)</sup> Sensor readout, different from pixel format

<sup>2)</sup> depends on the used interface

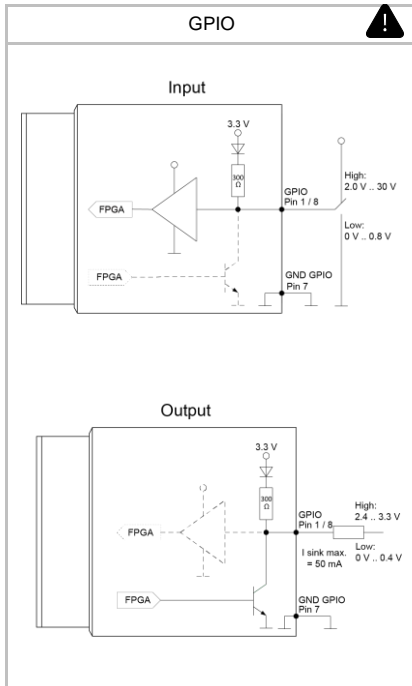
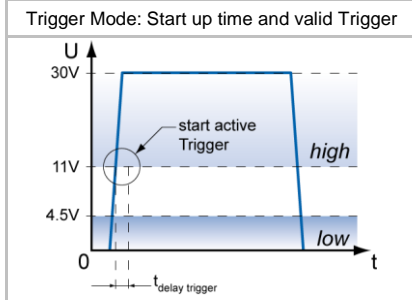
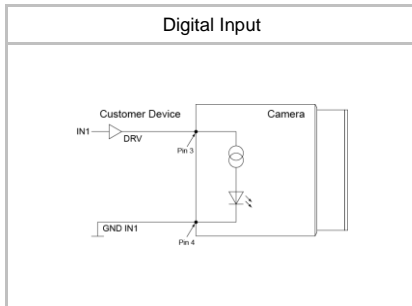

## Image Pre-Processing

Color Enhancement	-
Color Tolerance	-
Binning Horizontal	1 or 2
Binning Vertical	1 or 2
Defect Pixel Correction	yes, static DPC: Defect Pixel List with up to 512 Pixel Coordinates
Image Flipping	Horizontal, vertical
Fix Pattern Noise Correction	yes

## Process Synchronization

Trigger Mode	Off (Free Running), On (Trigger)
Trigger Overlap Type	Readout
Trigger Sources	Hardware (Line0, 1, 2), Software, Counter 1, 2 End, Action CMD (Action 1), All or Off fixed Trigger Delay out of treadout: <sup>1)</sup> 6 μsec @ 10 bit max. Trigger Delay during treadout: <sup>1)</sup> 12 μsec @ 10 bit
Trigger Delay	0 ... 2 sec, Tracking and buffering of up to 256 triggers
External Flash Sync	via Exposure Active $t_{\text{delay flash}} \leq 3 \mu\text{sec}$ , $t_{\text{duration}} = t_{\text{exposure}}$
Encoder Function	yes, via Counter and Trigger Source
PTP Function	-

## Digital I/Os

Lines	Input: Line 0, Output: Line3, GPIO: Line 1, Line 2
Line Sources (Output)	Off, ExposureActive, Timer1, ReadoutActive, UserOutput 1-3 and TriggerReady
Line Debouncer (Input)	Low and high signal separately selectable Debouncing Time 0 ... 5 msec, Step Size: 1 μsec

## Memory

Image Buffer	80 MB 32 Images (Trigger Mode) / 1 Image (Free Running Mode)
Non-volatile Memory	128 kb

## Network Interface Data

Interface	Gigabit Ethernet 1000BASE-T 1000 Mb/s/sec Fast Ethernet 100 BASE-T 100 Mb/s/sec
Ethernet IP Configuration	Persistent IP, DHCP, LLA
Packet Size	576 ... 9000 Byte, Jumbo Frames supported

## GigE Vision® Features

Events	DeviceTemperatureStatusChanged, EventLost, ExposureEnd, ExposureStart, FrameEnd, FrameStart, FrameTransferSkipped, GigEVisionError, GigEVisionHeartbeatTimeOut, PrimaryApplicationSwitch, Line0..2 FallingEdge, Line0..2 RisingEdge, TransferBufferFull, TransferBufferReady, TriggerOverlapped, TriggerReady, TriggerSkipped
Action CMD	yes, Action 1 for Trigger
Frame Counter	up to 2 <sup>32</sup>
Payload Size	0 ... 2621664 Byte
Timestamp	64 bit, resolution in nsec, increment = 8
Packet Delay	0 .. 2 <sup>32</sup> - 1 nsec
Packet Resend	Resend Buffer: 40 MB (16 Images)
GigE Vision	v2.0

<sup>1)</sup> Sensor readout, different from pixel format

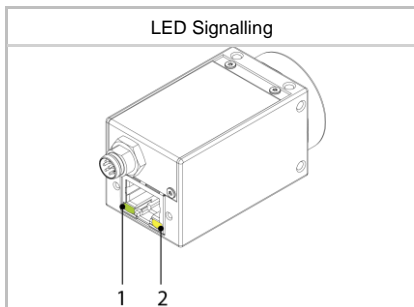
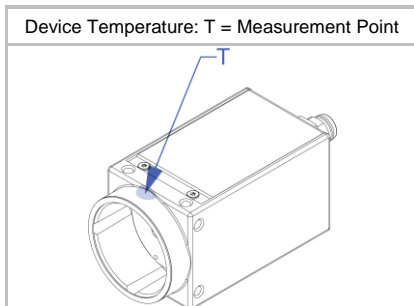
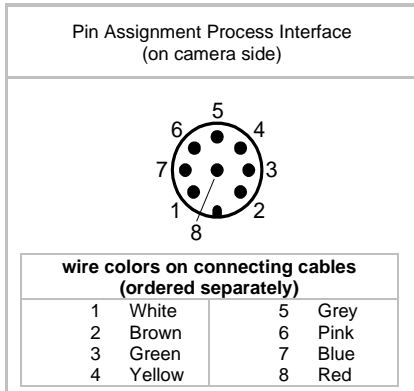
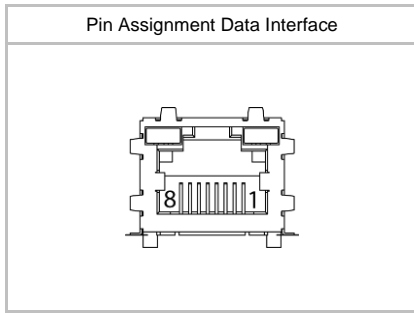

## Interfaces and Connectors

Data and Power Interface	Gigabit Ethernet	Transfer Rate	1000 Mbits/sec
	Fast Ethernet	Transfer Rate	100 Mbits/sec
Connector: 8P8C Modular Jack (RJ45), screwable TYPE090 (according to GigE Vision Mechanical Supplement)			
Assignment:		1 - MX1+	2 - MX1-
		3 - MX2+	4 - MX3+
		5 - MX3-	6 - MX2-
		7 - MX4+	8 - MX4-

Process Interface	Connector:	M8/8-pin (SACC-DSI-M8MS-8CON-M8-L180)
Assignment:		
1 - GPIO (Line2)		2 - Power Vcc
3 - IN1 (Line0)		4 - GND IN1
5 - Power VCC OUT		6 - OUT1 (Line3)
7 - GND (Power, GPIO)		8 - GPIO (Line1)

Caution



\* Note GPIOs: Ground loops are to be avoided and can lead to destruction of the device.

## Optical Data

Lens Mount	C-Mount
Optical Filter	-

## Mechanical Data

Housing	Zinc die casting, baked varnish
Protection Class	IP40 (with mounted lens and GigE cable)
Weight	120 g

Dimensions

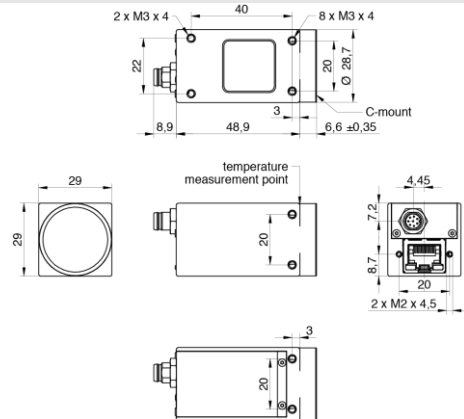

Additional Cooling Pipe	no
-------------------------	----

## Environmental Data

Storage Temperature	-20 °C ... +70 °C
Operating Temperature	0 °C ... +65 °C @ T = Measurement Point or 0 °C ... +75 °C @ internal Temperature Sensor
Note: Ambient temperature above 34 °C requires heat dissipation measures.	
Int. Temperature Sensor	yes, InHouse: step size 0.0625 °C, accuracy ±0.5 °C (typ) 0 °C ... +85 °C
Humidity	10 % ... 90 % non-condensing

## LED Signalling

LED	LED 1	Yellow static - Error Yellow flash - TX active
	LED 2	Green static - Link ON Green flash - RX active

## Electrical Data

Power Supply (ext.)	VCC: 12 ... 24 V DC $\pm$ 20% I: 125 ... 250 mA
Power over Ethernet	Class 1 device VCC: 36 ... 57 V DC I: 78 mA @ 48 VDC
Power Consumption	approx. 3.0 W @ 12 VDC and 94 fps approx. 3.7 W @ 48 VDC (PoE) and 94 fps (Factory Setting "Default")
Digital Input	Optocoupler $U_{IN(low)}$ : 0.0 ... 4.5 VDC $U_{IN(high)}$ : 11.0 ... 30.0 VDC $I_{IN}$ : 3.0 ... 10.0 mA min. Impulse Length: 2.0 $\mu$ sec
Digital Output	Optocoupler $U_{EXT}$ : 5 ... 30 V DC $I_{OUT}$ : max. 50 mA $t_{ON}$ = typ. 3 $\mu$ sec $t_{OFF}$ = typ. 40 $\mu$ sec
GPIO	direct, without optocoupler
GPIO used as Input:	$U_{IN(low)}$ : 0.0 ... 0.8 VDC $U_{IN(high)}$ : 2.0 ... 30.0 VDC min. Impulse Length: 2.0 $\mu$ sec
GPIO used as Output:	$U_{Out(low)}$ : 0.0 ... 0.4 VDC ( $I_{sink\ max}$ : 50 mA) $U_{Out(high)}$ : 2.4 ... 3.3VDC ( $I_{max}$ : 1 mA)
Caution 	* The General Purpose I/Os (GPIOs) are not potential-free and do not have an overrun cut-off. Incorrect wiring (overvoltage, undervoltage or voltage reversal) can lead to defects in the electronic system. Ground loops are to be avoided and can lead to destruction of the device.

## Conformity

Conformity	CE, RoHS, REACH, UL Recognized, KC
KC Registration No. / Date	R-R-BkR-VCXG2-25M / 02.11.2023
MTBF	62 years @ T = 45 °C / 40 years @ T = 60 °C T = Measurement Point

## GeniCam™ Features

Short Exposure Range	-
Timer	Timer Selector: Timer 1 TimerTriggerSource: Action 1, ExposureEnd, ExposureStart, FrameTransferSkipped, Line0, Software, TriggerSkipped and Off TimerDelay: 0 $\mu$ sec ... 2 sec, Step Size: 1 $\mu$ sec TimerDuration: 4 $\mu$ sec ... 2 sec, Step Size: 1 $\mu$ sec
Counter	Counter Selector: Counter 1, Counter 2 CounterValue: 0 ... 65535 Counter Event Source: Counter1End or Counter2End, ExposureActive, FrameTransferSkipped, FrameTrigger, TriggerSkipped, Line0..2 and Off Counter Reset Source: Counter1End, Counter2End, Line0..2 and Off

## GenICam™ Features

Sequencer	Sequencer Characteristics: up to 128 sets, up to 4 possible pathes for triggered set transitions, 6 trigger sources: Counter1End, Counter2End, ExposureActive, Line0..2, ReadoutActive, Timer1End Sequencer Parameters for Exposure, Gain, Trigger, ROI and Output: ExposureTime, CounterDuration, CounterEventActivation, CounterEventSource, CounterResetSource, ExposureMode, ExposureTime, Gain, Height, OffsetX, OffsetY, TriggerMode, UserOutputValue, UserOutputValueAll, Width
User Sets	Factory Settings: UserSet0 (read only) Freely Programmable: UserSet1, UserSet2, UserSet3 Parameters: any user definable Parameter
Acquisition Abort	Delay up to 6.8 msec
Chunk Data	yes, Chunk Selector: Binning, BlackLevel, CounterValue, DeviceTemperature, ExposureTime, FrameID, Gain, Height, Image, ImageControl, LineStatusAll, OffsetX, OffsetY, PixelFormat, SequencerSetActive, Timestamp, Width
Device Temperature	InHouse Event generation, if temperature status changed from Normal to High, High to Exceeded and Exceeded to Normal Exceeded (no image transfer) = max. internal temperature sensor + 1 °C
Device Link Throughput Limit	yes, up to max. Device Link Speed
Custom Data	yes, 128 Byte with CustomDataKonfiguration Mode
Optical Black Pixel Area	-
Black Level Auto Adjust	-
Calibration Data	yes, camera calibration values can stored: CalibrationMatrix, CalibrationMatrixNew, CalibrationFocallenght, CalibrationAngularAperture, GeometryDistortionValue: k1, k2, p1, p2, k3, CalibrationVector: tvec, rvec and CalibrationDataVersion
Device Indicator Mode (LED)	Active (Default), Inactive or ErrorStatus
SFNC Version	2.4.0

### Factory Settings after Start-Up

Ethernet IP Configuration	DHCP, LLA
Trigger Mode	Off (Free Running)
Analog Controls	Exposure Time: 4 msec, Gain: 0 dB, Offset: 0
Pixel Format	Mono8
Partial Scan	Off
Acquisition Frame Rate	Off
Timer/Counter/Sequencer	Off
Defect Pixel Correction	On
Fixed Pattern Noise Correction	ON
Optical Black Pixel Area	-
Black Level Auto Adjust	-
Digital Input	Line0, invert = false
Digital Output	Line3, invert = false, line source = Off
GPIO 1/2	Line1, Line2, invert = false, LineMode = Input
TriggerSource	All

### Partial Scan @ FullFrame, min Exposure, Mono8 (monochrome camera) or BayerRG8 (color camera)

	Resolution	max. fps acquisition	max. fps interface <sup>2)</sup>
SXGA	1280 x 1024	148	94
HD720	1280 x 720	209	133
XGA	1024 x 768	244	156
SVGA	800 x 600	391	256
VGA	640 x 480	595	401
CIF	352 x 288	1576	1214
QVGA	320 x 240	1969	1601
QCIF	176 x 144	2883	2883
SXGA	1280 x 1024	148	94
HD720	1280 x 720	209	133
XGA	1024 x 768	244	156
SVGA	800 x 600	391	256
VGA	640 x 480	595	401
CIF	352 x 288	1576	1214
QVGA	320 x 240	1969	1601
QCIF	176 x 144	2883	2883

<sup>2)</sup> depends on the used interface