

microGen
Energy Harvesting

Operating Manual

PMG93 CAM
Digital cam switch

EN-US

List of contents

1	About this document	4
1.1	Purpose	4
1.2	Warnings in this manual	4
1.3	Labels in this manual	5
1.4	Disclaimer	5
1.5	Scope of delivery	5
1.6	Name plate	5
1.7	Maintenance and service life	6
1.8	Approvals and warranty	6
1.9	Temperature range for operation and storage	6
2	General information	7
3	Transport and storage	8
3.1	Transport	8
3.2	Delivery inspection	8
3.3	Storage	8
4	Description	9
4.1	Structure	9
4.2	Mounting accessories (not included)	9
4.3	Required tools	9
4.4	Functionality	10
4.5	Switching outputs	10
4.5.1	Functions	10
4.5.2	Cam switches	10
4.5.3	Limit current at overload	11
4.6	LED activity indicator	11
5	Installation	12
5.1	Attaching coupling to cam switch	12
5.2	Cam switch mount onto the drive shaft of the slave unit	12
5.3	Maximum permitted tolerances for mounting errors when using the Baumer spring washer K 35	14
5.4	Notes when using a claw coupling (e.g. ROTEX®)	15
6	Electrical installation	16
6.1	Pin assignment web configurator	16
6.1.1	Mating connector (4-contact D-coded)	17
6.2	Terminal box web configurator	17
6.3	Mounting the terminal box	17
6.3.1	Terminals assignment	19
7	Commissioning	20

8 Switching outputs	21
9 Disassembly	22
9.1 Uninstall cam switch from drive shaft.....	22
9.2 Detaching coupling from cam switch.....	23
10 Maintenance	24
10.1 Cleaning the cam switch	24
11 Troubleshooting	25
11.1 Error indication via status LED	26
11.2 Return and repair	27
12 Technical data	28
12.1 PMG93 CAM	28
12.2 Dimensional drawing.....	29

1 About this document

1.1 Purpose

This operating manual (subsequently referred to as *manual*) allows the safe and efficient handling of the product .

The manual does not provide instructions on operating the machine in which the product is integrated. Information on this is found in the operating manual of the machine.

The manual is a constituent part of the product. It must be kept in the immediate vicinity of the product and must be accessible to personnel at all times.



Personnel must have carefully read and understood this manual before beginning any work. The basic prerequisite for safe working is compliance with all safety instructions and handling instructions given in this manual.

In addition, the local occupational health and safety regulations and general safety regulations apply.

The illustrations in this manual are examples only. Deviations are at the discretion of Baumer at all times.

1.2 Warnings in this manual

Warnings draw attention to potential personal injury or material damage. The warnings in this manual indicate different hazard levels:

Symbol	Warning term	Explanation
	DANGER	Indicates an imminent potential danger with high risk of death or serious personal injury if not being avoided.
	WARNING	Indicates potential danger with medium risk of death or (serious) personal injury if not being avoided.
	CAUTION	Indicates a danger with low risk, which could lead to light or medium injury if not avoided.
	NOTE	Indicates a warning of material damage.
	INFO	Indicates practical information and tips that enable optimal use of the devices.

1.3 Labels in this manual

Identifier	Usage	Example
<i>Dialog element</i>	Indicates dialog elements.	Click the OK button.
<i>Unique name</i>	Indicates the names of products, files, etc.	<i>Internet Explorer</i> is not supported in any version.
Code	Indicates entries.	Enter the following IP address: 192.168.0.250

1.4 Disclaimer

The manufacturer is not liable for personal injury and/or property damage resulting from improper use of the device.

1.5 Scope of delivery

Delivery includes:

- Digital cam switch
- 1 x instruction manual
- 1 x General information leaflet

In addition, the following information is available in digital form at www.baumer.com:

- Data sheet
- Web interface manual
- 3D CAD drawing
- Certificates (e.g. EU declaration of conformity)

1.6 Name plate

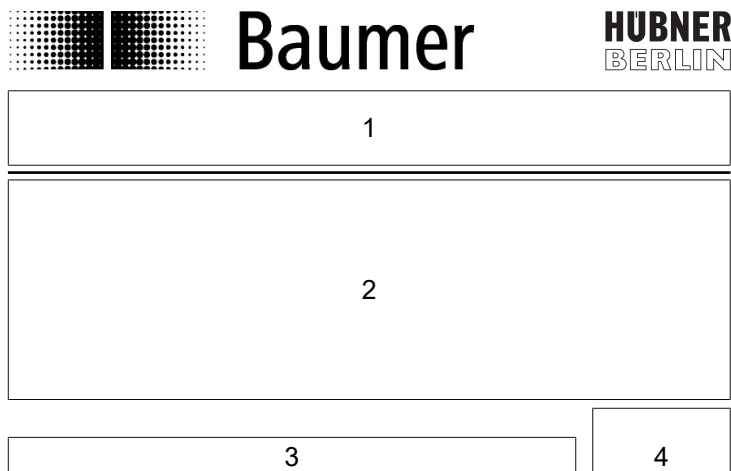

1	Product name, product code, material number	2	Serial number, technical data, MAC address
3	Baumer Website	4	Labels

1.7 Maintenance and service life

The device must not be opened unless for assembly and maintenance work as described in this instruction manual. Any repair or maintenance work requiring fully opening the device must be carried out by the manufacturer only.

Do not perform any modifications at the device.

The expected service life of the device depends on the ball bearings featuring permanent lubrication.

For any queries or subsequent deliveries refer to the product data specified on the device label, in particular type and serial number.

1.8 Approvals and warranty

Declaration of conformity according to the prevailing country-specific directives.

We grant a 2-year warranty in line with the conditions of the German Electrical and Electronic Manufacturers' Association (ZVEI).

INFO

warranty seal

Any breaking of the seal provided at the device will result in loss of warranty.

1.9 Temperature range for operation and storage

The storage temperature of the device ranges from -15 ... +70 °C (according to packaging)

The device operating temperature range ranges between -30 ... +85 °C, measured at housing.

2 General information

Intended use

This product is a precision device and serves the detection of items, objects, or physical measurement variables and the preparation or provision of measured values as electric variables for the higher-level system.

Unless specifically labeled, this product may not be used in explosive environments.

Commissioning

Assembly, installation, and calibration of this product may only be performed by a specialist.

Installation

Only use the fasteners and fastener accessories intended for this product for installation. Outputs not in use must not be wired. Unused wires of cable outputs must be insulated. Do not go below the permissible cable bending radii. Disconnect the system from power before the product is electrically connected. Use shielded cables to prevent electro-magnetic interference. If the customer assembles plug connections on shielded cables, then EMC-version plug connections should be used and the cable shield must be connected to the plug housing across a large surface area.

Disposal (environmental protection)



Used electrical and electronic devices may not be disposed of in household waste. The product contains valuable raw materials that can be recycled. Therefore dispose of this product at the appropriate collection point. For additional information visit www.baumer.com.

3 Transport and storage

3.1 Transport

NOTICE

Material damage due to improper transport.

- a) Ensure maximum diligence when unloading the delivered packages as well as when transporting them inside the company.
- b) Note the information and symbols on the packaging.
- c) Only remove packaging immediately before mounting.

3.2 Delivery inspection

Upon receipt immediately inspect the delivery for completeness and transport damage.

Claim any defect as soon as it is detected. Damages can only be claimed within the applicable claims deadlines.

In case of externally visible transport damage, proceed as follows:

Instruction:

- a) Do not accept the delivery or only with reservations.
- b) Note the scope of the damage on the transport documents or the delivery slip of the carrier.
- c) Initiate the claim.

3.3 Storage

Store the product at the following conditions:

- Use the original packaging for storage.
- Do not store outdoors.
- Store dry and free from dust.
- Do not expose to aggressive media.
- Keep away from the sun.
- Avoid mechanical agitation.
- Storage temperature: -15 ... +70 °C (according to packaging)..
- When storing for longer than 3 months, regularly check the general state of all parts and the packaging.

4 Description

4.1 Structure

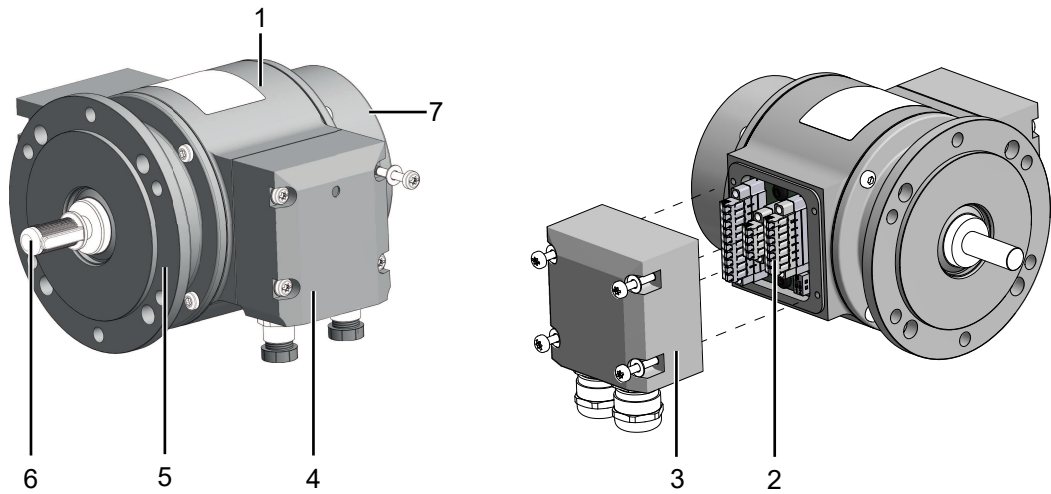

III. 1: Structure PMG93 CAM

1	Digital cam switch	2	Terminal box Bus connection
3	Terminal box cover	4	Terminal box web configurator
5	EURO flange B10	6	Solid shaft with key
7	LED activity indicator		

4.2 Mounting accessories (not included)

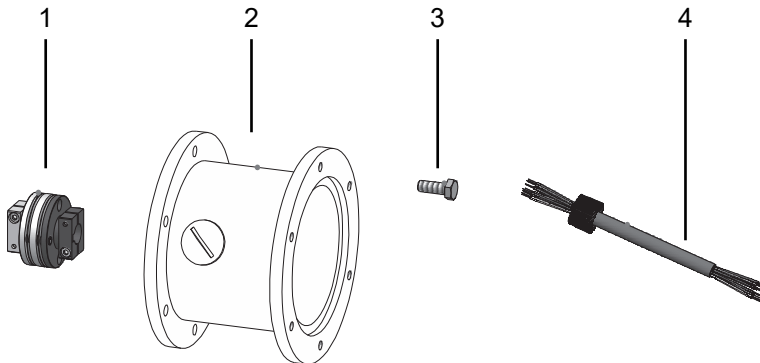

III. 2: Mounting accessories

1	Spring washer coupling K35, available as accessory	2	Attachment device, customized accessory
3	Mounting screw attachment device, M6x16 mm (ISO 4017)	4	Terminal box connection cable

4.3 Required tools

- 2.5 mm
- 10 mm, 22 mm
- 20 mm

4.4 Functionality

The PMG93 CAM is a digital cam switch to accurately determine positions. The ten switching outputs in the separate terminal box are used for position monitoring. The switching outputs are freely programmable via web interface.

4.5 Switching outputs

The digital cam switch features switching outputs for cam switches (CA1 to CA10). The switching outputs can be configured and activated or deactivated in the software interface.

4.5.1 Functions

Configuration	Push
Switch open	high impedance
Switch closed	Uca

4.5.2 Cam switches

Cam switches are based on the digitized absolute angular position.

Resolution	24 bit (singleturn 12 bits, multiturn 12 bits)
Absolute angular position	0 ... 16777215

The output convert state and the switching hysteresis of each cam switch are realized by four switching points and the internal absolute position values.

Configuration of the cam switch hysteresis depends on system requirements. The cam switch outputs are not inverted by default; configuration as non-inverted or inverted is via web interface.

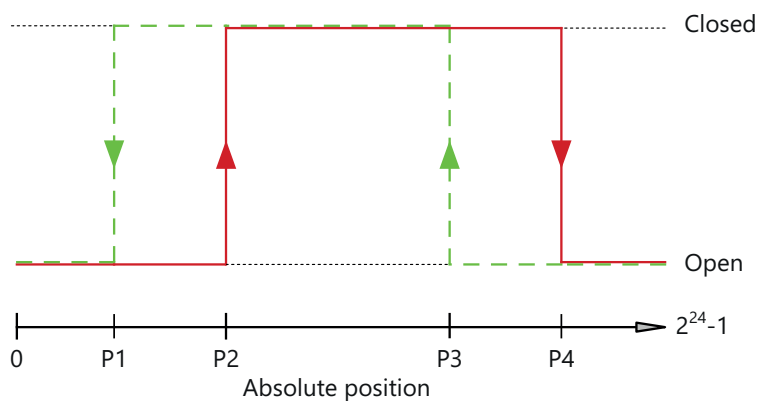

III. 3: Non-inverted output behavior of cam switches

To ensure proper cam switch functionality and operation, configuration should consider the following switching point requirements:

$$0 \leq P1 < P2 < P3 < P4 \leq 16777215$$

However, at high speed there is still the risk of the cam controller being neglected in the event of incorrect parameterization, particularly if the cam length parameter is too short. It's up to the user to verify parameterization.

The minimum parameter for cam switch length should exceed the angular distance to cover within 10 μ s at maximum possible speed.

$$P4 - P2 \text{ (or } P3 - P1) = \text{upper limit (} \frac{\text{Speed}_{\text{max}} \text{ rpm}}{60} \cdot 100 \cdot 10^{-6} \cdot 2^{12} \text{)}$$

Example: In a system running at maximum speed of 3000 rpm, the minimum length of the cam switch parameter should be 100 μ s.

$$P4 - P2 \text{ (or } P3 - P1) = \text{upper limit (} \frac{3000}{60} \cdot 100 \cdot 10^{-6} \cdot 2^{12} \text{)} = 21$$

Baumer recommends parameterization of relatively wide cams to ensure reliable performance.

4.5.3 Limit current at overload

The switching outputs provide various diagnostic functions:

- Overload and short-circuit detection
- Excess heat recognition
- Detection of an open load

In the event of an overload, the load is limited to a maximum value. The limitation causes a voltage drop at the switching outputs, as a result of which the switching voltage UCA is no longer present at the switching output. If the switching outputs heat up too much, for example in the course of an overload, they are automatically opened to prevent damage to the electronics. An open load, is detected by the switching outputs as soon as the load current falls below a minimum value in the closed state.

Also see about this

[Technical data \[▶ 28\]](#)

4.6 LED activity indicator

LED	Description
P1	N/A
P2	N/A
Status	Status LED, error indicator

5 Installation

NOTICE

Equipment damage due to mechanical impact

Strong vibration may lead to overload by constraining force.

- a) Never apply force. If properly performed, all components can be mounted smoothly.

NOTICE

Equipment damage by adhering liquids

Sticky liquids may damage sensing unit and ball bearings. Disassembling a device which is stuck to the axis can lead to destruction.

- a) Do not use adhesive liquids to fasten the device.

5.1 Attaching coupling to cam switch



INFO

For connecting the cam switch to the drive shaft of the downstream device, Baumer recommends Baumer spring washer K 35. Baumer Spring washer K 35 can be pushed onto the drive shaft without axial pressure.

Instruction:

- a) Attach the coupling at a torque of 1 Nm according to the related mounting instructions.
- b) When using the Baumer K 35 spring washer observe the maximum permitted tolerances for mounting errors (see [Maximum permitted tolerances for mounting errors when using the Baumer spring washer K 35 \[▶ 14\]](#)).

5.2 Cam switch mount onto the drive shaft of the slave unit

⚠ DANGER

Injuries caused by shaft rotation

Hair and clothing can get tangled in rotating shafts. This can lead to serious injuries.

- a) Make sure that the device is idle.
- b) Prior to performing any work at the device, make sure power supply is and will remain off.

⚠ DANGER

Explosion

Sparks may cause fire or explosion.

- a) Do not use the device in the near vicinity of explosive or highly flammable materials.

NOTICE**Equipment damage by mechanical overload**

Rigid mounting may cause overload by constraining forces.

- a) Do not limit the device mobility.
- b) Observe the mounting instructions.
- c) Adhere to the specified distances and/or angles.

NOTICE**Severe runout errors of the drive shaft reduce service life and may cause angular errors.**

Severe runout errors of the drive shaft cause vibrations that cut down on the encoder service life and may cause angular errors.

- a) Keep runout errors of drive shaft down to a minimum (recommended: ≤ 0.03 mm; maximum: ≤ 0.2 mm).

NOTICE**Signal interference due to missing grounding**

Lack of grounding can cause signal interference.

- a) Ensure grounding via the housing and the flange.

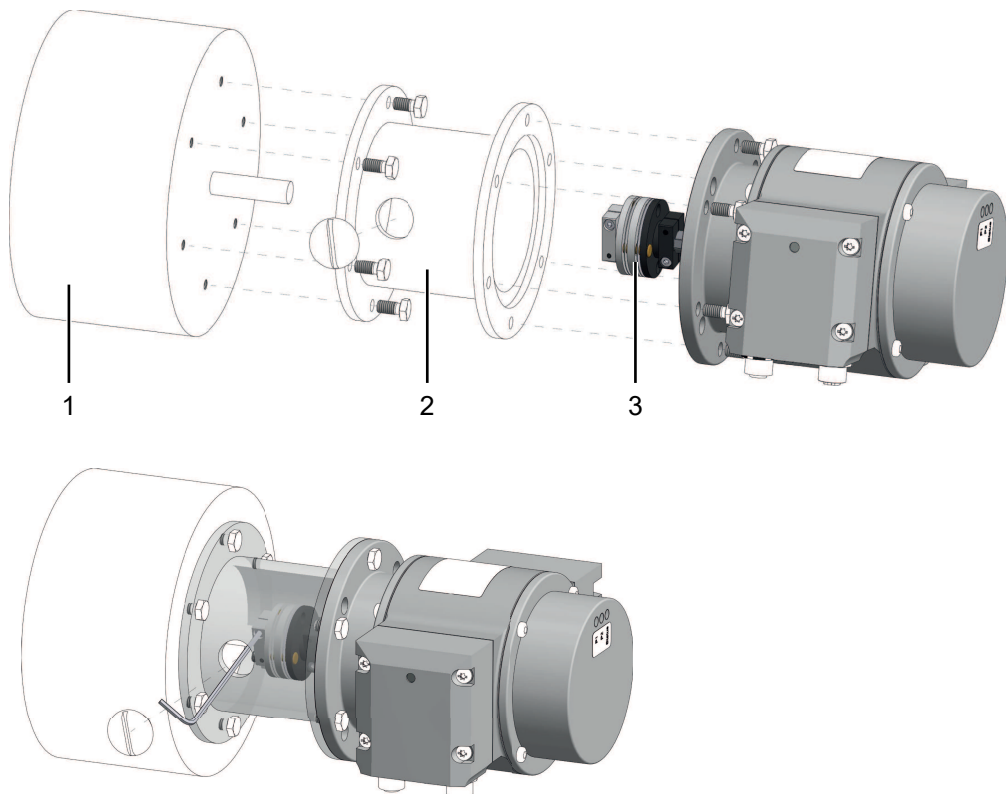

III. 4: Mount cam switch, mounting device and coupling to the downstream device

1	Slave	2	Attachment device (customized)
3	Coupling		

Tool

- 10 mm
- 2.5 mm

Instruction:

- a) Install the cam gear in a way preventing the electrical connection from any direct water ingress.
- b) Apply grease onto the drive shaft of the slave unit.
- c) Fasten the mounting device (customer-specific) properly at the slave unit.
- d) Push the cam switch coupling onto the drive shaft of the downstream device.
- e) Fasten the cam switch properly on the mounting device (customer-specific) of the downstream device.
- f) Mount the coupling onto the drive shaft of the slave unit at a torque of $1.3 \pm 10\%$ Nm. Observe the coupling mounting instructions.

5.3 Maximum permitted tolerances for mounting errors when using the Baumer spring washer K 35

NOTICE

Damage to the cam switch ball bearings.

Hard impacts of coupling parts imposed on the drive shaft may damage the ball bearings.

- a) Prevent any hard impacts of the drive shaft on coupling parts.

Instruction:

- a) Mount the drive with small angular error and parallel offset.
- b) Note the following allowable mounting errors:

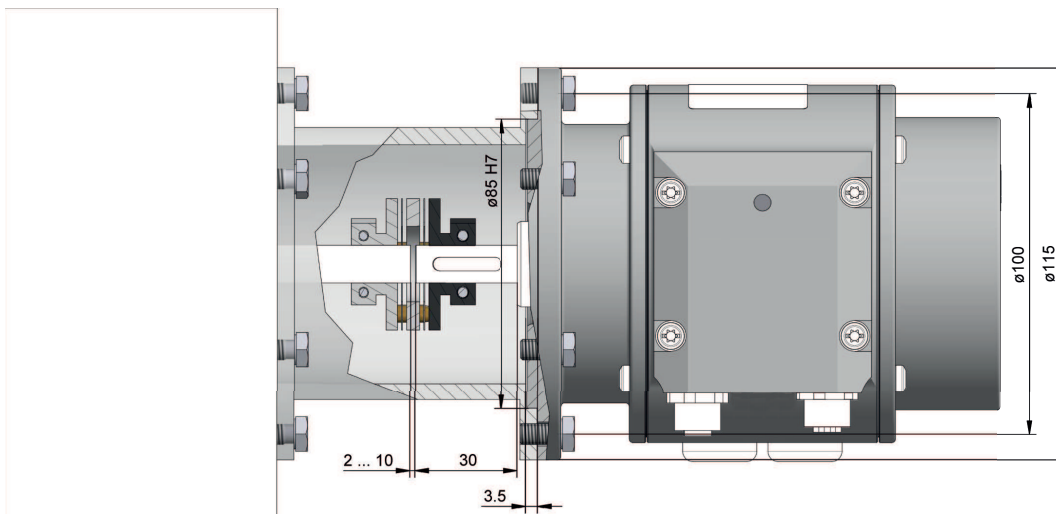

Permitted parallel misalignment

Permitted angle error

Permissible axial movement

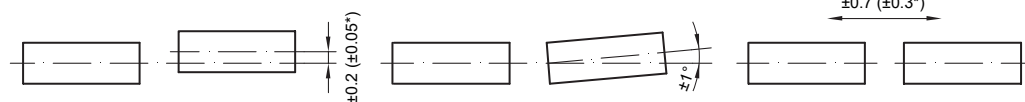

* With insulated plastic hub

III. 5: Permissible mounting errors (dimensions in mm)

5.4 Notes when using a claw coupling (e.g. ROTEX®)

NOTICE

Damage to the cam switch due to incorrect coupling installation.

Jammed coupling halves (claws face to face) may damage the cam switch.

- Make sure the coupling halves are not jammed.
- Prevent the device shaft from any direct axial stops.

Instruction:

- Observe the distances L and $L1$ when mounting the claw coupling.

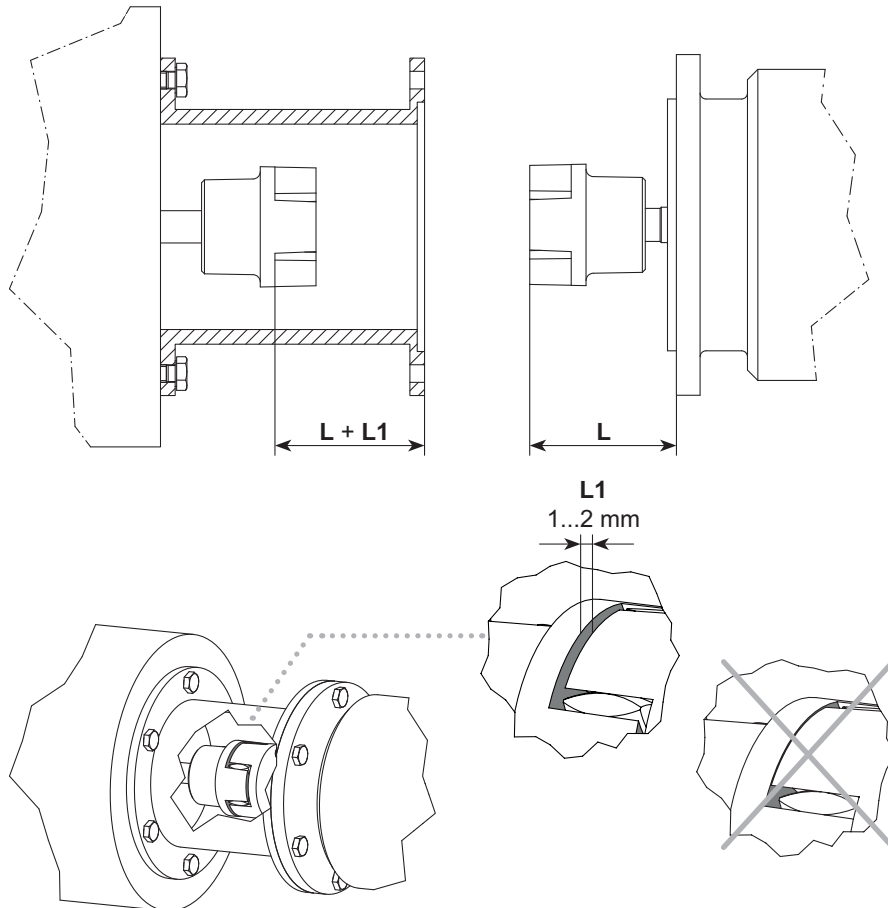

III. 6: Correct assembly of a claw coupling

6 Electrical installation

⚠ DANGER

Injury by to secondary damage

Encoder failure or incorrect signals may entail system control errors.

- a) Eliminate secondary encoder damage by the relevant safety precautions in the downstream electronics.

NOTICE

Sensor damage due to faulty power supply.

The sensor can be damaged due to faulty power supply.

- a) Operate the sensor only with protected low voltage and safe electrical isolation of protection class III.

NOTICE

Sensor damage or unintended operation due to work on live parts.

Work on live parts may lead to unintentional operation.

- a) Disconnect the power before carrying out any cable.
- b) Disconnect the power before connecting or disconnecting electrical connections.

NOTICE

Sensor damage by excessive switching voltage.

The sensor's overload limit is for protection only and not intended as limit for the permanently switching voltage.

- a) Make sure that the maximum permitted switching voltage is not exceeded.

6.1 Pin assignment web configurator

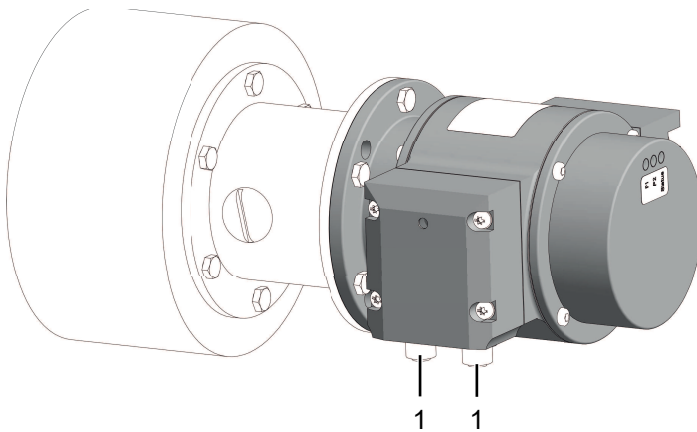

III. 7: Connections PMG93 CAM

- 1 Mating connector (4-contact, D-encoding)

6.1.1 Mating connector (4-contact D-coded)

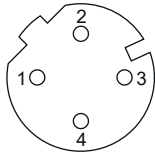

III. 8: Mating connector (4-contact, D-coded)

PIN	Connection	Description
1	TxD+	Data transmitted +
2	RxD+	Data received +
3	TxD-	Data transmitted -
4	RxD-	Data received -

6.2 Terminal box web configurator

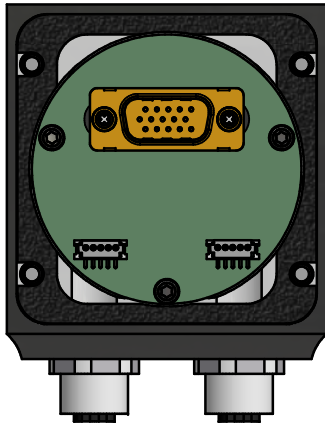

III. 9: Terminal box PMG93 CAM

6.3 Mounting the terminal box

NOTICE

Equipment damage by ESD

The electronic components in the device are sensitive to high voltage

- Do not touch terminals or electronic components.
- Protect output terminals from external voltage.
- Do not exceed the maximum operating voltage.

NOTICE

Equipment damage by soiling

Soiling may cause short circuiting and damage of the sensing unit.

- Ensure absolute cleanliness at all times when working with the device.
- Prevent any oil or grease from penetrating inside the device.

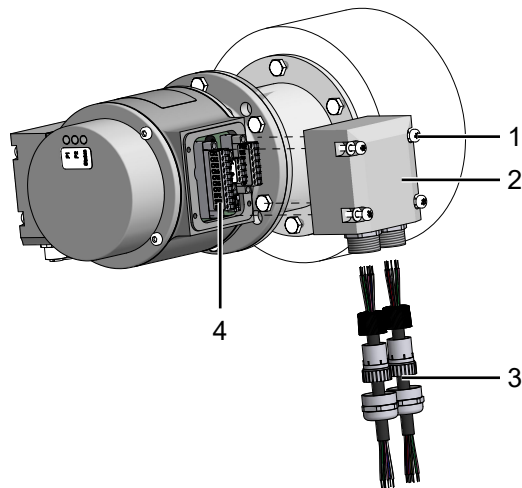

III. 10: Terminal box PMG93 CAM

1	Torx / slotted screw (M4x32 mm)	2	Terminal box cover
3	Cable glands (M20 x 1.5 mm for cable diameter 5...13 mm)	4	Connection terminals (wire cross-section $\leq 1.5 \text{ mm}^2$)

Tool

-  22 mm
-  20 mm

Instruction:

- a) Only use cables with an appropriate diameter.
- b) Consider potential voltage drops in extended cable length.
- c) Feed the cables through the cable gland into the terminal box.
- d) Connect the cables to the terminals in the terminal box.
- e) When using only one cable port, seal the second one with the attached metal cap.
- f) Screw the cable shield to the connection box.
- g) Fasten the terminal box cover of at a torque of 2-3 Nm.

6.3.1 Terminals assignment

NOTICE

Operating voltage present at the outputs will damage the cams.

The cam switch might be damaged by operating voltage present at the outputs.

- a) Make sure that no operating voltage is present at the outputs.

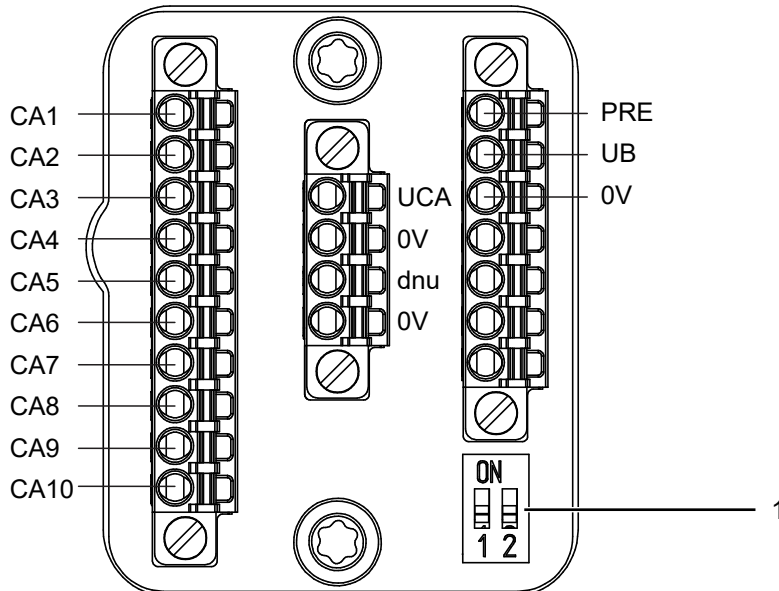

III. 11: Connection terminals PMG93 CAM

1 DIP switch default settings

Terminal	Significance
PRE	Preset ¹
UB	Power supply
0 V	Ground
UCA	Cam switch power supply
CA1 ... CA10	Cam switch
dnu	Do not use

¹ To trigger the preset, a pulse greater than 8 V with a length of at least 50 ms must be applied.

7 Commissioning

⚠ DANGER**Explosion**

Sparks may cause fire or explosion.

- a) Do not use the device in the near vicinity of explosive or highly flammable materials.
-

⚠ DANGER**Burns caused by heat**

The device heats up at high speeds. There is a risk of getting burned after use.

- a) Avoid overheating the device.
 - b) Wear suitable protective gloves and clothing.
-

Instruction:

- ♦ Follow the instructions in the software manual for device commissioning and parameterization.

8 Switching outputs

The digital cam switch features switching outputs for cam switches (CA1 to CA10). The switching outputs can be configured and activated or deactivated in the software interface.

9 Disassembly

NOTICE

Equipment damage due to mechanical impact

Strong vibration may lead to overload by constraining force.

- a) Never apply force. If properly performed, all components can be uninstalled smoothly.
- b) Use only suitable tools to uninstall.

NOTICE

Equipment damage by adhering liquids

Sticky liquids may damage sensing unit and ball bearings. Disassembling a device which is stuck to the axis can lead to destruction.

- a) Do not use adhesive liquids to fasten the device.

9.1 Uninstall cam switch from drive shaft

⚠ DANGER

Burns caused by heat

The device heats up at high speeds. There is a risk of getting burned after use.

- a) Avoid overheating the device.
- b) Wear suitable protective gloves and clothing.

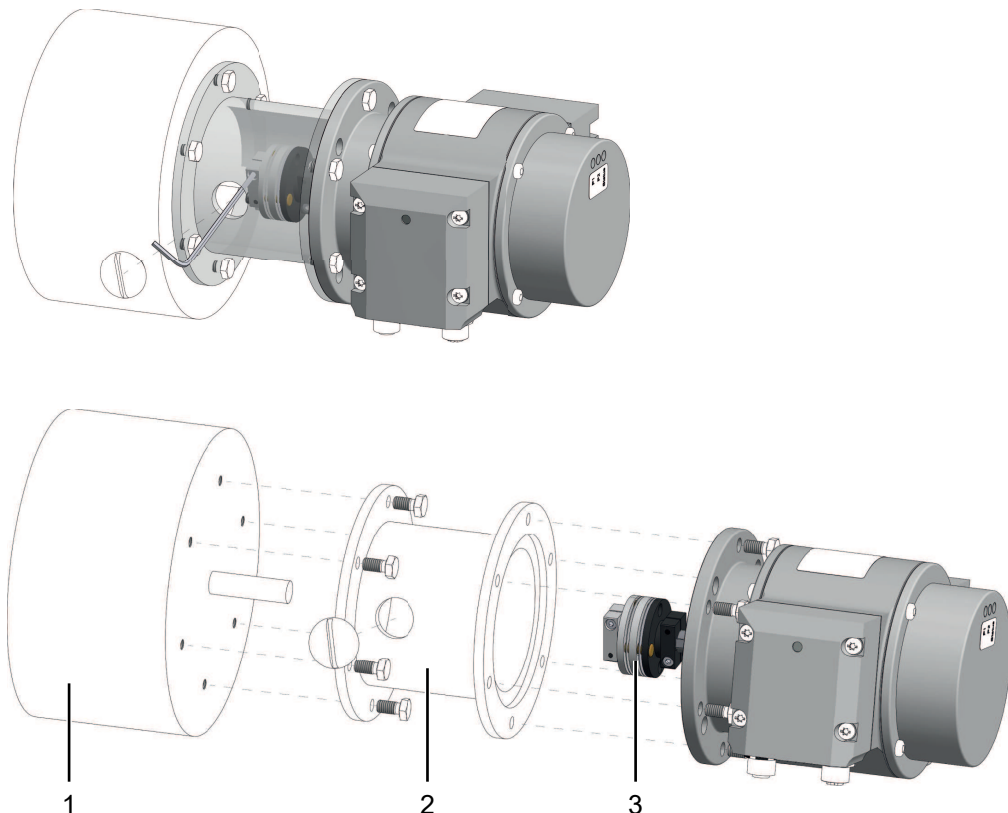

III. 12: Detach cam switch, mounting device and coupling

1	Slave	2	Attachment device (customized)
3	Coupling		

Tool

-  2.5 mm
-  10 mm

Instruction:

- a) Disconnect all electrical connections.
- b) Loosen the the coupling on the drive shaft.
Observe the notes in the data sheet and the coupling assembly instructions.
- c) Loosen the fastening of the cam switch at the mounting device of the drive.
- d) Pull the cam switch from the attachment device of the drive machine.
- e) Uninstall the attachment device.
- f) Detach the coupling from the cam switch.

9.2 Detaching coupling from cam switch

Instruction:

- ◆ Detach the coupling from the cam switch according to the installation instructions.

10 Maintenance

The sensor is maintenance-free. No special preventive maintenance is required. Regular cleaning and visual inspection of the plug connections are recommended.

10.1 Cleaning the cam switch

Outside cleaning

When cleaning the outside of the cam switch, make sure to use cleaning agents that do not affect housing surface and seals.

NOTICE

Material damage due to improper cleaning.

Unsuitable cleaning agents and methods can cause leaks and material damage to cam switch, seals or connections.

- a) Always check the suitability of the cleaning agent for the surface to be cleaned.
 - b) Do not use scouring agents, solvents or other aggressive cleaning agents.
 - c) Do not scrape off soiling with sharp-edged items.
-

Inside cleaning

No inside cleaning of the cam switch required.

11 Troubleshooting

NOTICE

Do not open or repair the cam switch

Individual failures relate to the installation conditions.

- a) Do not open or perform any repair work.
- b) Approach your Baumer contact person. Please specify the product data on the product label, in particular type and serial number.

a) In the event of error, check all connecting cables upon proper functionality and being free from damage.

b) Also verify cam switch shield and grounding.

c) Restart cam switch:

Device configuration > Web interface & firmware > Restart sensor



INFO

If voltage drops below the specified supply, the rotary encoder may switch off, as otherwise proper cam switch operation and position monitoring is no longer ensured.

- a) If so,, check power supply and restart cam switch.



INFO

Firmware update: In the event of a faulty firmware update, the device will be in bootloader mode.

11.1 Error indication via status LED

LED	Potential error cause	Description	Troubleshooting
<i>green</i>	-	<ul style="list-style-type: none"> Standard operation (no error present) 	-
<i>yellow continuous</i>	Bootloader mode	<ul style="list-style-type: none"> Firmware error / not ok Cam switch is in bootloader mode 	<ul style="list-style-type: none"> Execute firmware update via Ethernet and Rescue website
<i>red flashing</i>	Switching output: no/low switching voltage	<ul style="list-style-type: none"> Voltage for cam switch not present or too low 	<ul style="list-style-type: none"> Connect encoder voltage that is in the defined value range
	Switching output: open load	<ul style="list-style-type: none"> No load present or connected to one or more switching outputs (e.g. caused by cable break) 	<ul style="list-style-type: none"> Check every switching output connection Ensure min. load requirements at switching outputs (see technical data)
	Switching output: Overload/short circuit	<ul style="list-style-type: none"> Overload or short circuit present at one or more switching outputs 	<ul style="list-style-type: none"> Check every switching output connection Ensure max. load requirements at switching outputs
	Switching output: excess temperature	<ul style="list-style-type: none"> Electronics on thermal overload at one or more switching outputs (e.g. caused by short circuit or overload) 	<ul style="list-style-type: none"> Check every switching output connection Ensure max. load requirements at switching outputs
	Supply voltage too low	<ul style="list-style-type: none"> Cam switch supply is below minimum limit 	<ul style="list-style-type: none"> Voltage off Set voltage in the defined value range Voltage ON again
	Website not accessible	<ul style="list-style-type: none"> Internal web page of the cam switch is damaged/faulty 	<ul style="list-style-type: none"> Execute firmware update via Ethernet and Rescue website
<i>red continuous</i>	Factory Reset	<ul style="list-style-type: none"> Factory reset released by DIP switch in the terminal box 	<ul style="list-style-type: none"> Complete Factory Reset Set DIP switch to OFF



INFO

More information on status and potential cam switch errors is available at the internal cam switch web page.

11.2 **Return and repair**

In case of complaints, please contact the relevant sales company.

12 Technical data

12.1 PMG93 CAM

Electrical Data	
Operating voltage U_b	9-30 V DC
Operating current without load	≤ 500 mA
Sensing principle	Optical
Steps per turn	4096 / 12 bits
Number of revolutions	4096 / 12 bits
Incremental output	TTL/RS422, HTL (optional)
Pulses per revolution	2048
Programming interface	Ethernet
Data rate (programming interface)	10/100 Mbit/s
Programmable parameters	Cam switch, network, default settings
Electrical (cam switches)	
Output configuration	push / open-drain
Resolution	1 step (1 LSB)
Switching voltage U_{ca}	9 -30 V DC
Output current per switch	≥ 10 mA / ≤ 150 mA
Switching delay	≤ 40 ms
Electrical (presets input)	
High level (input)	≥ 8 V DC
Low level (input)	≤ 5 V DC
Maximum input voltage	≤ 30 V DC
Input power	< 10 mA
Mechanical	
Dimensions (flange)	$\varnothing 115$ mm
Shaft type	$\varnothing 11$ mm solid shaft
Flange	EURO flange B10
Operating speed	≤ 3500 rpm
Operating temperature	-30 ... +85 °C
Terminal	Terminal box for parameterization Terminal box web configurator

12.2 Dimensional drawing

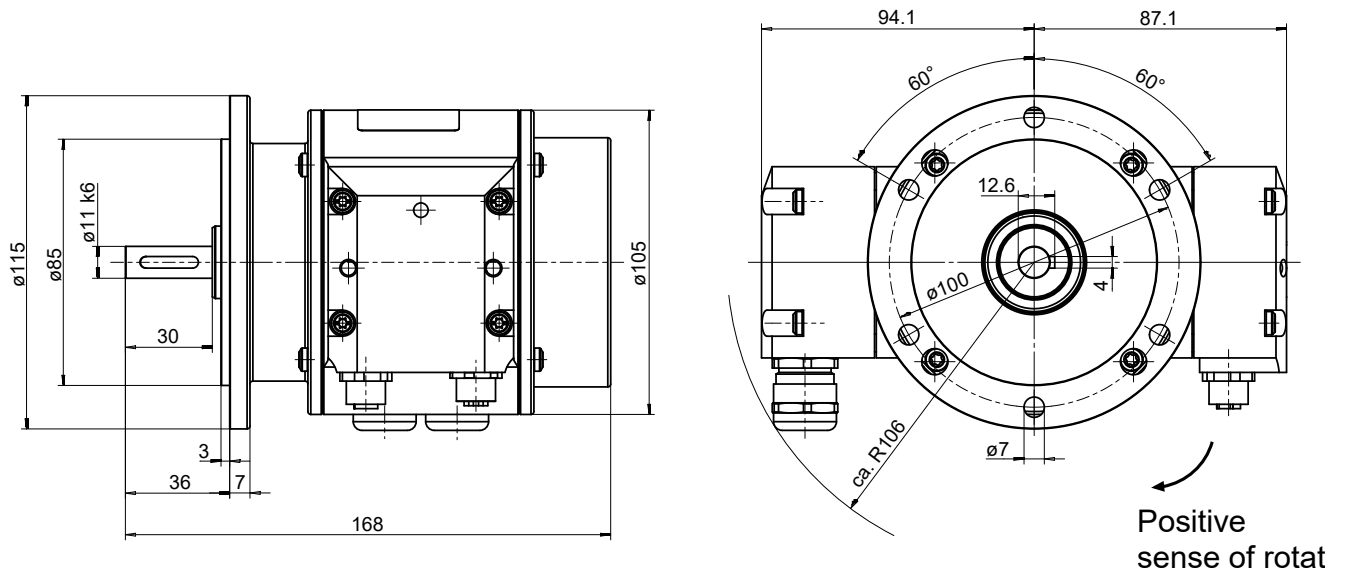

III. 13: PMG93 CAM dimensions (in mm)

List of illustrations

III. 1	Structure PMG93 CAM	9
III. 2	Mounting accessories	9
III. 3	Non-inverted output behavior of cam switches	10
III. 4	Mount cam switch, mounting device and coupling to the downstream device	13
III. 5	Permissible mounting errors (dimensions in mm)	14
III. 6	Correct assembly of a claw coupling.....	15
III. 7	Connections PMG93 CAM	16
III. 8	Mating connector (4-contact, D-coded).....	17
III. 9	Terminal box PMG93 CAM	17
III. 10	Terminal box PMG93 CAM	18
III. 11	Connection terminals PMG93 CAM	19
III. 12	Detach cam switch, mounting device and coupling	22
III. 13	PMG93 CAM dimensions (in mm).....	29

