

# HOG890

Incremental HeavyDuty encoders with three switches for demanding machinery and asynchronous drives

## Overview

- Protection IP66
- Shaft insulation 3.5 kV
- Corrosion protection CX
- Operating temperature -40...+100 °C
- Cable length up to 350 m (HTL-P) or 550 m (TTL)
- Sealed and user-friendly field termination
- Extended protection circuit
- Parameterization
- Standstill, speed, direction and status monitoring and display with Baumer Sensor Suite or using the switches

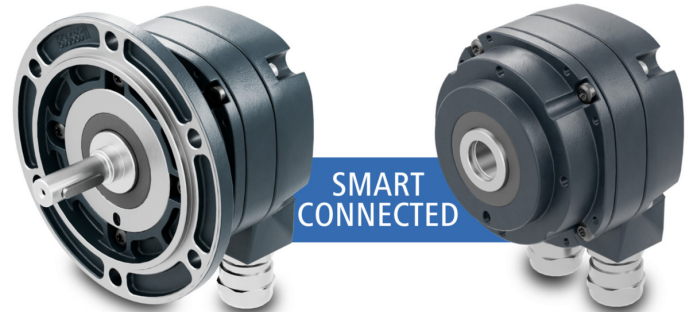

Picture similar

**HUBNER**  
BERLIN  
A Baumer Brand



**HeavyDuty**  
70 years of experience



**1+1=1**  
Combination

## Technical data

### Technical data - electrical ratings

Voltage supply	4.75...30 VDC (Vin = Vout, HTL/TTL)
Consumption w/o load	≤100 mA
Pulses per revolution	1 ... 32768
Further pulses per revolution	Freely parameterizable with Baumer Sensor Suite
Phase shift	Typ. 90 °
Duty cycle	Typ. 50 %
Reference signal	Zero pulse, width 90° or 180°
Sensing method	Optical
Output frequency	≤200 kHz
Output signals	K1, K2, K0 + inverted
Output stages	HTL-P (power linedriver) TTL
Shaft insulation	Suitable up to 3.5 kV
Transmission length	≤350 m at 100 kHz (HTL-P) ≤550 m at 100 kHz (TTL)
Interference immunity	EN 61000-6-2
Emitted interference	EN 61000-6-4
Approval	CE UL approval / E217823 CSA

### Technical data - mechanical design

Size (flange)	ø90 mm, length 72 mm
Shaft type	ø12G7 mm (blind hollow shaft) ø16G7 mm (blind hollow shaft) ø11 x 30 mm (solid shaft with key)
Admitted shaft load	≤350 N axial ≤450 N radial
Mounting type	Hollow shaft: central screw Solid shaft: EURO flange B10
Protection EN 60529	IP 66

### Technical data - mechanical design

Operating speed	≤6000 rpm (mechanical)
Operating torque	≤6 Ncm
Rotor moment of inertia	160 gcm <sup>2</sup>
Material	Housing: aluminium, powder-coated Shaft: stainless steel
Operating temperature	-40...+100 °C
Resistance	IEC 60068-2-6 Vibration 20 g, 10-2000 Hz IEC 60068-2-27 Shock 300 g, 6 ms 1 Mio. brake shocks
Corrosion protection	IEC 60068-2-52 Salt mist for ambient conditions CX according to ISO 12944-2
Connection	Terminal box with pluggable push in terminal blocks and cable gland M20

### Technical data - digital switches

Function	Combination with three digital switches: <ul style="list-style-type: none"> <li>• Overspeed and underspeed detection</li> <li>• Standstill and creep monitoring</li> <li>• Direction of rotation display</li> <li>• Warning or failure events</li> <li>• Parameterizable with Baumer Sensor Suite</li> </ul>
Switching outputs	Output (Push)
Number of switching outputs	3

### Technical data - digital speed switches

Function	Detection of overspeed and underspeed
Max. number of switching outputs	3

## HOG890

Incremental HeavyDuty encoders with three switches for demanding machinery and asynchronous drives

### Technical data

#### Technical data - digital speed switches

Parametrization	Speed range Hysteresis Switching delay
Speed setting resolution	0.1 rpm
Switching accuracy	± 2 % (up to ±1 rpm at 50 rpm)

#### Technical data - standstill monitoring

Function	Detection of standstill and creep
Max. number of switching outputs	1

#### Technical data - standstill monitoring

Parametrization	Dwell time Standstill position window
Activation Speed	±2 rpm

#### Technical data - direction of rotation

Function	Detection and display of the direction of rotation
Max. number of switching outputs	1
Parametrization	Hysteresis

### Optional

- ATEX

# HOG890

Incremental HeavyDuty encoders with three switches for demanding machinery and asynchronous drives

## Baumer Sensor Suite

### Monitoring

The following information is displayed with the Baumer Sensor Suite:

- Encoder settings
- Speed and position over time
- Current speed, position and temperature
- Encoder status
- Minimum and maximum temperature over entire service life
- Total operating time
- Total revolutions
- Switch monitoring
  - Switch status
  - Speed over time per switch with switching window
  - Switch status over time
  - Direction of rotation status
  - Status of standstill monitoring

### Parameterization

The following parameters can be set via USB-C access with the Baumer Sensor Suite:

- Number of lines per mechanical revolution
- Output stages
- Reference length and phase
- Setting the user units
- Switching outputs
  - Switching active high, active low
  - Speed switch
  - Direction of rotation switch
  - Standstill switch
- Time behavior for switching outputs
  - Minimum switch-on time (On)
  - Minimum switch-off duration (Off)

### Parameterization - encoder

Pulses per revolution	Selection: 50, 500, 512, 1000, 1024, 2048, 2500, 4096, 5000 + free input
Output stages	HTL-P (power linedriver) TTL
Rotating direction	CW, CCW
Width of zero pulse	90°, 180° (reference signal)

### Parameterization - digital switches

Min. switch-on time	1...1000 ms
Min. switch-off time	1...1000 ms

### Parameterization - digital speed switch

Function	Speed switch with adjustable speed limits and switching delay to filter out short-term speed peaks
Switching output	Active high / active low
Upper/lower speed range	±2 ... 6000 rpm
Hysteresis	0...50 %
Switching delay time	0...5000 ms (0 ms default)

### Parameterization - standstill monitoring

Function	Reliable creep detection through position monitoring if the speed falls below a specified speed within a defined time window
Switching output	Active high / active low
Dwell time	10...1000000 ms
Creep Window	1...100°

### Parameterization - direction of rotation

Function	Direction detection with adjustable hysteresis
Switching output	Active high / active low
Hysteresis	1...100°

# HOG890

Incremental HeavyDuty encoders with three switches for demanding machinery and asynchronous drives

## Terminal assignment

Output (push)

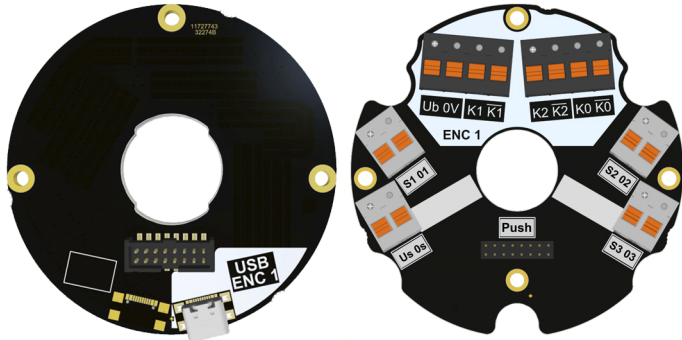

## Terminal significance

$U_b$	Voltage supply
0V	Ground
K0	Zero pulse (reference signal)
$\overline{K0}$	Zero pulse inverted
K1	Output signal channel 1
$\overline{K1}$	Output signal channel 1 inverted
K2	Output signal channel 2
$\overline{K2}$	Output signal channel 2 inverted
Us	Voltage supply - push output
0s	Ground - push output
S1	Push switching output 1
S2	Push switching output 2
S3	Push switching output 3
01	Ground - push output 1
02	Ground - push output 2
03	Ground - push output 3
USB ENC1	USB-C for parameterization

## Output signals

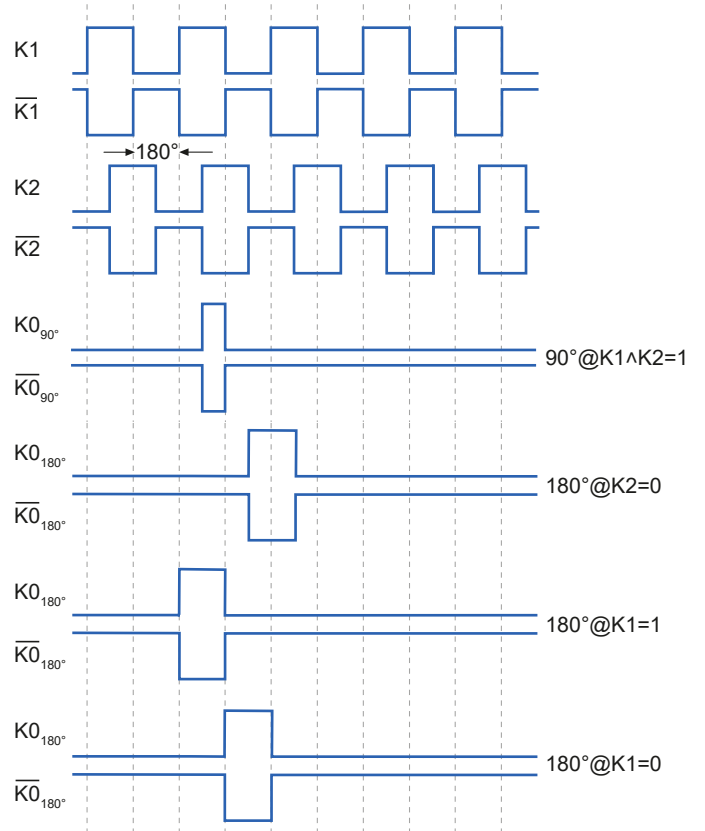

With positive direction of rotation / clockwise, with view on the encoder shaft

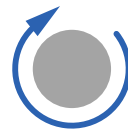

# HOG890

Incremental HeavyDuty encoders with three switches for demanding machinery and asynchronous drives

## Derating

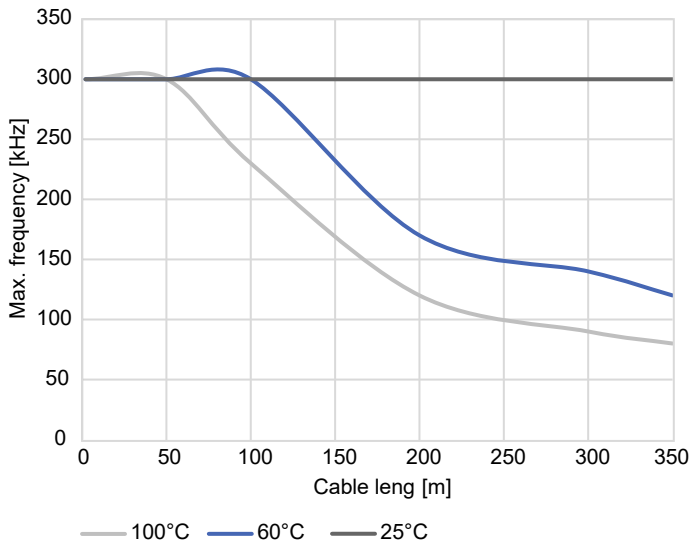

Max. frequency over cable length and temperature, Ub 24 V

## Dimensions

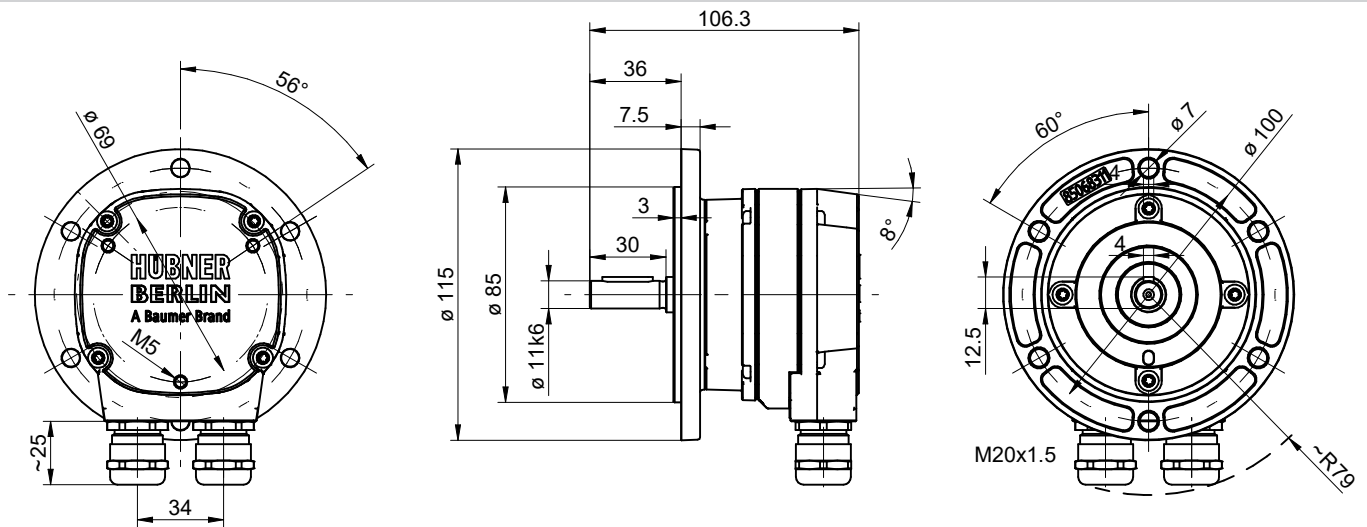

Solid shaft, cable gland

# HOG890

Incremental HeavyDuty encoders with three switches for demanding machinery and asynchronous drives

## Dimensions

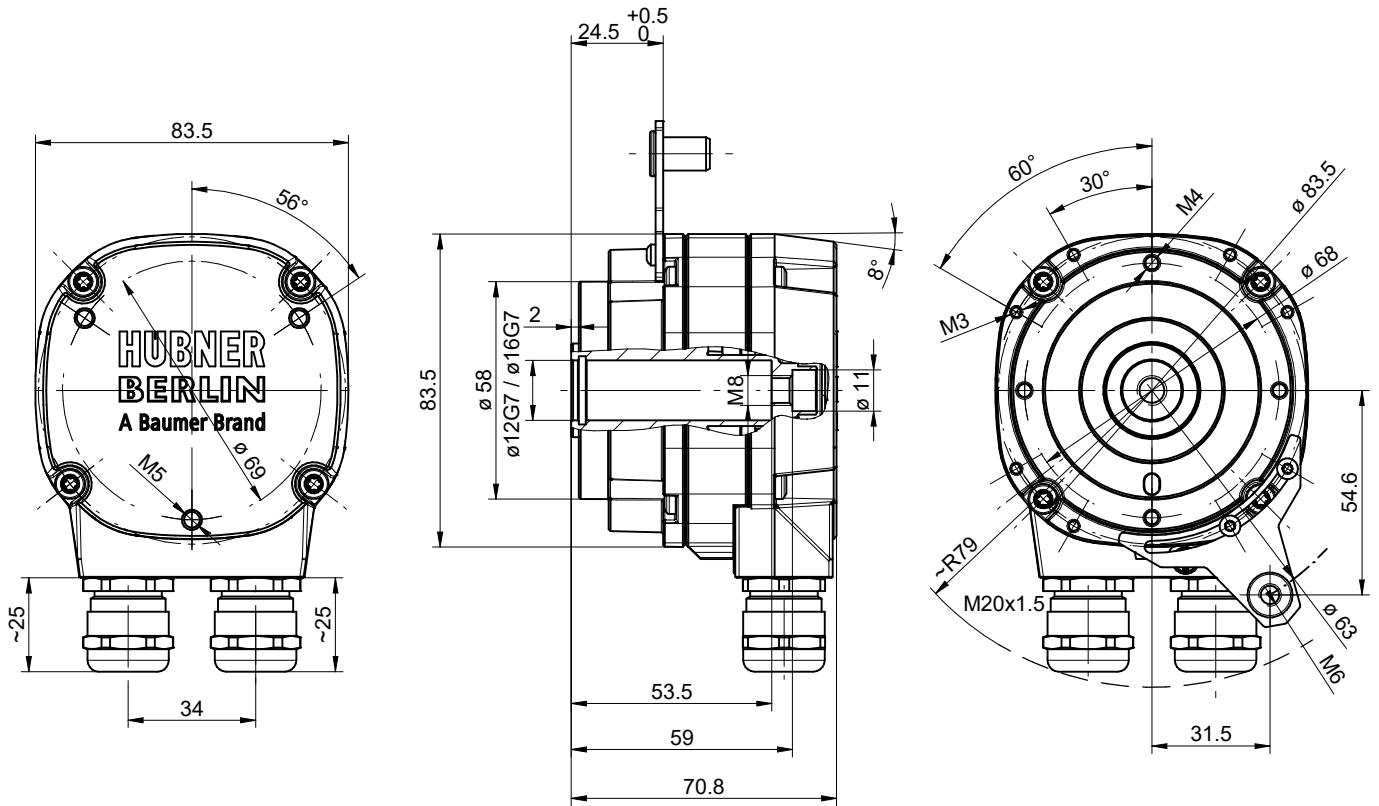

Blind hollow shaft, cable gland (torque plate can be mounted at different positions)

## HOG890

Incremental HeavyDuty encoders with three switches for demanding machinery and asynchronous drives

### Ordering reference

Product	Shaft	Pulses per revolution, output	Connection	Comment	Material number
HOG890	Solid shaft ø11 mm	Parameterization & monitoring at customer	2 x cable gland M20	3 x push	EHOG890-11730711
	Blind hollow shaft ø12G7 mm	Parameterization & monitoring at customer	2 x cable gland M20	3 x push	EHOG890-11730712
	Blind hollow shaft ø16G7 mm	Parameterization & monitoring at customer	2 x cable gland M20	3 x push	EHOG890-11730713